



International  
Energy Agency  
Secure  
Sustainable  
Together



PARTNER COUNTRY SERIES

# ***Development Prospects of the ASEAN Power Sector***

Towards an Integrated  
Electricity Market



International  
Energy Agency  
Secure  
Sustainable  
Together



PARTNER COUNTRY SERIES

# ***Development Prospects of the ASEAN Power Sector***

Towards an Integrated  
Electricity Market

## INTERNATIONAL ENERGY AGENCY

The International Energy Agency (IEA), an autonomous agency, was established in November 1974. Its primary mandate was – and is – two-fold: to promote energy security amongst its member countries through collective response to physical disruptions in oil supply, and provide authoritative research and analysis on ways to ensure reliable, affordable and clean energy for its 29 member countries and beyond. The IEA carries out a comprehensive programme of energy co-operation among its member countries, each of which is obliged to hold oil stocks equivalent to 90 days of its net imports. The Agency's aims include the following objectives:

- Secure member countries' access to reliable and ample supplies of all forms of energy; in particular, through maintaining effective emergency response capabilities in case of oil supply disruptions.
- Promote sustainable energy policies that spur economic growth and environmental protection in a global context – particularly in terms of reducing greenhouse-gas emissions that contribute to climate change.
- Improve transparency of international markets through collection and analysis of energy data.
  - Support global collaboration on energy technology to secure future energy supplies and mitigate their environmental impact, including through improved energy efficiency and development and deployment of low-carbon technologies.
  - Find solutions to global energy challenges through engagement and dialogue with non-member countries, industry, international organisations and other stakeholders.

IEA member countries:



Australia  
Austria  
Belgium  
Canada  
Czech Republic  
Denmark  
Estonia  
Finland  
France  
Germany  
Greece  
Hungary  
Ireland  
Italy  
Japan  
Korea  
Luxembourg  
Netherlands  
New Zealand  
Norway  
Poland  
Portugal  
Slovak Republic  
Spain  
Sweden  
Switzerland  
Turkey  
United Kingdom  
United States

**International Energy Agency**  
Secure  
Sustainable  
Together

© OECD/IEA, 2015

**International Energy Agency**  
9 rue de la Fédération  
75739 Paris Cedex 15, France

[www.iea.org](http://www.iea.org)

Please note that this publication is subject to specific restrictions that limit its use and distribution. The terms and conditions are available online at [www.iea.org/t&c/](http://www.iea.org/t&c/)

The European Commission also participates in the work of the IEA.

## Foreword

The power sector is fundamental to the energy outlook for Southeast Asia. The demand for power is projected to grow faster than any other final form of energy, accounting for 58% of growth in total demand. The Association of Southeast Asian Nations (ASEAN) needs to add 354 gigawatts of additional capacity for power generation by 2040, which more than doubles today's capacity and calls for investments of USD 618 billion in generation and USD 690 billion in the transmission and distribution of this power.

Page | 3

The challenges in meeting Southeast Asia's demand in the power sector stem from the need to secure resources for generation, to invest in additional capacity and grid development, and to do so in sustainable and cost-effective ways. The International Energy Agency (IEA) publication *Energy Technology Perspectives 2012 (ETP 2012)* underlined the challenges ASEAN is facing across all sectors in reaching the *ETP 2012 2°C Scenario*, due to the dominant use of fossil fuels (particularly coal-fired generation). Ensuring sufficient financial resources and enabling governance environments are key to drive forward the development and use of reliable, sustainable and affordable power systems. The environmental implications of power generation have to be understood and managed accordingly. Efforts towards sustainable development – for example, through harnessing the existing hydropower potential of the Greater Mekong area – could assist the decarbonisation of electricity generation by ASEAN. An interconnected power system could further enhance the development and integration of its variable renewable power generation capacity. This would enhance not only the sustainability of ASEAN's power sector but also increase its general electricity security.

Together with the ten ASEAN Ministers of Energy, the IEA agreed to undertake this study as a priority project when we signed the memorandum of understanding between ASEAN and the IEA in September 2011. The analysis builds on prior work and, specifically, on the findings of the ASEAN chapter in *ETP 2012* and the projections of the *World Energy Outlook Special Report 2015: Southeast Asia Energy Outlook*.

The analysis and findings of this study focus on the short- and medium-term challenges for ASEAN electricity market integration and governance, and the technical models required to enhance physical cross-border interconnector development and trading. Overcoming these challenges will eventually lead to the establishment of subregional electricity markets that could in turn advance deeper integrated regional electricity systems, thus giving rise to a more secure, reliable electricity supply to support ASEAN's flourishing economies.

Dr. Fatih Birol

Executive Director

International Energy Agency

## Acknowledgements

This report was prepared by the Southeast Asia Desk and the Gas, Coal and Power Sector Division of the International Energy Agency (IEA). The analysis was designed and directed by Florian Kitt, Matthew Wittenstein, and Dennis Volk.<sup>1</sup> Principal contributors to the report were Noor Miza Muhamad Razali, Lars Dittmar, and Aaron Praktijnjo. Other key contributors were Yerim Park, Shelly Hsieh, Holly Heinrich, and Eleonora Antar. Lisa-Marie Grenier provided essential support.

Barbara Zatlokal carried editorial responsibility.

The report benefited from valuable inputs, comments and feedback from other experts within the IEA, in particular Laszlo Varro, Keisuke Sadamori, Rebecca Gaghen, Misako Takahashi, Shigetoshi Ikeyama, Toshiyuki Shirai, and Cedric Philibert. Thanks also go to the Agency's Communication and Information Office for their help in producing the report and to Bertrand Sadin for graphics.

The report was published in partnership with the Association of Southeast Asian Nations (ASEAN) Secretariat, the ASEAN Centre of Energy, and the Heads of ASEAN Power Utilities / Authorities (HAPUA). We in particular appreciated the support and co-operation provided by Syaiful Ibrahim, Secretary, HAPUA, Christopher Zamora, Office Manager, ACE, Megasari Widyaty, Head, Energy, ASEAN, Rabiah Al Adawiyah T. Hussein, Infrastructure Division, ASEAN.

This report was prepared under the memorandum of understanding between the ASEAN and the IEA and its preparation endorsed by ASEAN Ministers of Energy in Vientiane, Lao PDR, in 2014. The publication benefited from the substantive and financial contribution of ASEAN under the ASEAN-Australia Development Cooperation Program Phase II (AADCP II).

A workshop organised by the ASEAN Center of Energy, HAPUA, and the IEA was held on March 2015 in Jakarta to gather essential input to this study. The workshop participants have contributed valuable new insights, feedback, and data for this analysis.

Many experts from outside of the IEA provided input, commented on the underlying analytical work, and reviewed the report. Their comments and suggestions were of great value. They include: Dejan Ostojic, Terence Surlles, and Thierry Lefevre.



This publication is supported by the Government of Australia through the ASEAN-Australia Development Cooperation Program Phase II (AADCP II).

The Permanent Delegation of the Republic of Korea to the Organisation for Economic Co-operation and Development (OECD) contributed substantial funding to the report as well.

---

<sup>1</sup> During the writing of this report Dennis Volk changed employers – he now works as Programme Officer at the International Renewable Energy Agency (IRENA). His comments on behalf of IRENA contributed substantially to the renewable energy chapter.

# Table of contents

<b>Foreword .....</b>	<b>3</b>
<b>Acknowledgements .....</b>	<b>4</b>
<b>Executive summary .....</b>	<b>8</b>
<b>Development prospects of the ASEAN power sector .....</b>	<b>10</b>
ASEAN energy co-operation .....	10
The APG .....	11
Challenges for regional power integration .....	14
Country overviews .....	16
Brunei .....	17
Cambodia .....	17
Indonesia .....	17
Lao PDR .....	18
Malaysia .....	18
Myanmar .....	18
Philippines .....	19
Singapore .....	19
Thailand .....	19
Viet Nam .....	20
<b>Power sector governance .....</b>	<b>21</b>
Historical development, ownership and investment .....	21
Conventional organisational structures of the power sector .....	22
Power sector investment costs .....	23
Generation costs .....	23
Network services .....	27
Price regulation .....	28
Electricity tariff setting .....	29
The restructured market model .....	30
Reform efforts in the ASEAN countries .....	33
<b>Implications of renewable energy integration for ASEAN markets .....</b>	<b>38</b>
Renewable energy in ASEAN .....	38
Support schemes for RE .....	41
Integration of renewable resources into national power systems .....	43
<b>Developing regional electricity markets .....</b>	<b>46</b>
Benefits of integration .....	46
Security of supply .....	47
System efficiency .....	48
Quantifying the benefits of system integration .....	51

The role of regulators in establishing regional electricity markets .....	52
Electricity security regulations.....	53
Co-ordinated planning .....	53
Cost allocation of transmission development and wheeling charges .....	54
Revising network codes .....	55
System monitoring.....	56
Policies to support power sector integration.....	58
Models of co-ordination .....	59
Co-ordination and consolidation in the ASEAN context.....	66
<b>Conclusion and recommendations.....</b>	<b>68</b>
<b>References .....</b>	<b>71</b>
<b>Acronyms, abbreviations and units of measure .....</b>	<b>74</b>

### List of figures

<b>Figure 1.1 •</b> Power supply trilemma .....	10
<b>Figure 1.2 •</b> Net electricity imports in ASEAN countries.....	11
<b>Figure 1.3 •</b> ASEAN Power Grid and the three subregions identified by HAPUA (May 2014).....	12
<b>Figure 1.4 •</b> Average annual investment in the power sector .....	15
<b>Figure 1.5 •</b> Population growth in ASEAN countries and examples of 15-year historical trend for kWh consumption per capita .....	16
<b>Figure 1.6 •</b> Installed capacity in each ASEAN member country .....	16
<b>Figure 2.1 •</b> Two monopoly models of electricity market .....	22
<b>Figure 2.2 •</b> Installed capacity and generation mix for Indonesia in 2013 .....	23
<b>Figure 2.3 •</b> Proportion of CAPEX and OPEX in LCOE for various technologies .....	24
<b>Figure 2.4 •</b> LCOE as a function of discount rate .....	25
<b>Figure 2.5 •</b> LCOE as a function of fuel cost (7% discount rate) .....	26
<b>Figure 2.6 •</b> Comparison of coal-fired electricity generation by technology and average efficiency .....	27
<b>Figure 2.7 •</b> Schematic structure of the power grid .....	27
<b>Figure 2.8 •</b> Electricity tariff components for Singapore .....	29
<b>Figure 2.9 •</b> Single-buyer model of electricity market based on vertically integrated version (A) and unbundled version (B) .....	30
<b>Figure 2.10 •</b> OECD electricity sector regulation indicators (OECD NMR database) .....	32
<b>Figure 2.11 •</b> Private investment in ASEAN electricity sectors between 1990 and 2013 .....	33
<b>Figure 3.1 •</b> Countries with renewable generation support schemes.....	42
<b>Figure 4.1 •</b> Hypothetical demand curves with non-coincident peaks.....	49
<b>Figure 4.2 •</b> Total demand, hypothetical coincident and non-coincident peaks.....	49
<b>Figure 4.3 •</b> Peak demand in 16 European countries, 2011 .....	50
<b>Figure 4.4 •</b> Variability of demand in nine European countries, first two weeks of January 2011 .....	50
<b>Figure 4.5 •</b> Variability of wind output in four European countries, first two weeks of January 2011 .....	51
<b>Figure 4.6 •</b> Summary of the potential net benefits of European market integration in 2030 (EUR/MWh) .....	52
<b>Figure 4.7 •</b> Key responsibilities of regulators.....	53

<b>Figure 4.8</b> • Proposed transmission development plans for members of the EIPC .....	54
<b>Figure 4.9</b> • Data handling in a regional market .....	56
<b>Figure 4.10</b> • Example of coexistence for co-ordination and complete consolidation .....	58
<b>Figure 4.11</b> • Unidirectional trade based on electricity cost differences .....	59
<b>Figure 4.12</b> • Bilateral trade between neighbouring countries .....	60
<b>Figure 4.13</b> • A foreign IPP selling power to a national power utility in a neighbouring country ..	62
<b>Figure 4.14</b> • Purchase and resale of energy by an intermediate country .....	63
<b>Figure 4.15</b> • Trade between two countries with third-party wheeling charges .....	63
<b>Figure 4.16</b> • Multi-buyer, multi-seller market.....	64
<b>Figure 4.17</b> • Possible integration structure for the ASEAN region.....	66

### List of tables

<b>Table 1.1</b> • APAEC programme areas.....	11
<b>Table 1.2</b> • Planned interconnections until 2020 .....	13
<b>Table 1.3</b> • Selected electricity market integration indicators (estimated) .....	20
<b>Table 2.1</b> • State of electricity regulation in ASEAN member countries .....	36
<b>Table 3.1</b> • ASEAN electricity generation by source (TWh) .....	38
<b>Table 3.2</b> • Hydroelectric generation, supply, export and import in Lao PDR.....	39
<b>Table 3.3</b> • Price-based instruments and their characteristics.....	41
<b>Table 3.5</b> • Support schemes in ASEAN countries .....	42
<b>Table 3.6</b> • Technology classes for RE.....	43
<b>Table 4.1</b> • Summary for co-ordination vs. complete consolidation.....	58

### List of boxes

<b>Box 1.1</b> • Thailand-Lao PDR hydropower interconnection .....	13
<b>Box 1.2</b> • Singapore-Malaysia interconnection and the Austro-Hungarian exchange .....	14
<b>Box 2.1</b> • IRP as an alternative to power development plans .....	35
<b>Box 2.2</b> • Case study: Philippines – From private sector investment to electricity wholesale markets.....	37
<b>Box 3.1</b> • Hydropower development in Southeast Asia .....	39
<b>Box 4.1</b> • Case study: The 2003 power outage in the northeastern United States and Canada ..	48
<b>Box 4.2</b> • Case study: Price coupling of regions in the European Union .....	57
<b>Box 4.3</b> • Managing interconnections .....	61
<b>Box 4.4</b> • Case study: Southern African Power Pool.....	65



## Executive summary

Investment in additional generating capacity and grids that is both sustainable and cost-effective will be the biggest challenge in meeting the expected growth in demand of the power sector in the Association of Southeast Asian Nations (ASEAN) countries. At present, both the availability and the affordability of fuel supply are being prioritised over environmental sustainability; hence fossil fuels, particularly coal- and gas-fired turbines, dominate the fuel mix. Efforts to use energy resources effectively are hampered by the uneven distribution of these resources and different levels/rates of investment and economic development among ASEAN member countries. Sufficient financial resources, enabling governance environments, and regional co-ordination are critical drivers for reliable, sustainable and affordable power systems.

A regional ASEAN Power Grid (APG) would help ASEAN countries meet their rising energy demand, improve access to energy services and reduce the costs of developing an energy infrastructure. In essence, the APG aims to connect countries with surplus power generation capacity to those facing a deficit. An interconnected power system could also further enhance the development and integration of variable renewable power generation capacity.

Good power sector governance and efficiency can be achieved under both liberalised and regulated markets. Principally, development of the power sector needs a strong, reliable and depoliticised governance framework. A precondition for such a governance framework is an independent and strong regulator. To ensure this, the regulatory authority must be formally separated from the executive branch (i.e. ministries, etc.), and governed by statute without executive political influence on the regulation process.

Currently, most ASEAN power systems operate under a single-buyer market structure. Competitive wholesale electricity markets exist only in Singapore and the Philippines. Independent power producers (IPPs) play a critical role in the single-buyer arrangement. Initially, the intent of IPPs is to relieve the budgets of governments of the financial burden of power sector investment and to promote competition, which should result in greater power sector efficiencies and lower rates for consumers. However, these gains can only be achieved if the appropriate regulatory environment is in place. On the other hand, in liberalised markets, efficiency can only be obtained by having transparent procedures, fair grid access and a substantial number of market players.

Electricity prices for final consumers generally consist of the costs of generation, network, retailing, taxes and levies as well as profit margins. The market and regulatory system need to ensure that all these components are fully covered to stimulate future investment. Tariffs should be set in such a way as to cover these costs, although care should be given to provide support for low-income households.

ASEAN countries have good potential to further harness renewable energy (RE), especially hydro, geothermal, biomass/biogas, wind and solar power. Recognising the benefits that RE provides in terms of energy security, both economic and environmental, most ASEAN countries have set individual targets and support schemes which directly support the regional target. The establishment of a regional power system may offer better access to multi-technology and geographically dispersed RE. Furthermore, system integration may boost RE generation as variable sources can be supported by flexible generation technologies. In the short term, this could lead to considerably greater exploitation of ASEAN's hydroelectric resources, while significantly higher targets for modern renewable energy can be achieved only in the medium to long term.

Two primary advantages of system integration are the increase in security of supply and efficiency. Larger service territories allow for the pooling of generating resources, thus taking advantage of the benefits of generation diversity. This diversity also has the ability to aggregate demand. Power systems can be integrated through co-ordination or complete consolidation; however, both arrangements can coexist, as exemplified by the United States system. In the ASEAN context, complete consolidation is impractical, not least because of geographical factors, but also because complete consolidation would necessitate the establishment of a single market operator with authority that stretches across multiple jurisdictions, requiring changes in national laws. Consolidation is achievable, however, at a subregional level. Between the various subregions, co-ordination is a more efficient option for power sector integration.

Regulators play a pivotal role in a regional market. Their key responsibilities include establishing electricity security regulations, co-ordinated planning, allocating the cost of transmission development, revising network codes and system monitoring. It is also critical to define and designate the operation and maintenance responsibilities of each regulator early on, to avoid overlap and misunderstanding of roles. Additionally, matters pertaining to cross-border energy transfer must be managed in line with practice in the local electricity market.

Finally, this report concludes with several important observations and recommendations. It recognises that even if a fully consolidated regional market may not be achievable in the foreseeable future, ASEAN member countries should work closely together to set common long-term goals. The medium-term target should be harmonisation of grid codes and reliability standards. To ensure this, an independent regional regulator should be established and given a mandate to look after the common benefits and interests of the ASEAN member countries.

# Development prospects of the ASEAN power sector

## ASEAN energy co-operation

Page | 10

Southeast Asia is the third-fastest growing region in the world, based on real gross domestic product (GDP) growth. By the end of 2015, ASEAN is expected to launch the ASEAN Economic Community (AEC), with the goal to enhance ASEAN's economic performance and trade flows. ASEAN's high economic growth comes at a cost: its rapidly increasing energy demand has driven up its energy security risks. Though ASEAN countries are rich in energy resources, meeting this increasingly high energy demand will be challenging. The uneven distribution of energy resources and different levels of economic development among ASEAN countries complicate efforts to effectively use energy resources to meet demand not just between but also within countries.

In particular, the power sector trilemma<sup>1</sup> of the sustainability, availability and affordability of fossil fuels (oil, gas, coal) poses challenges for power supply in Southeast Asia. While growing regional power demand leads to increased competition for available energy resources and tightens the availability of conventional fuel supply, sustainability concerns call for increasingly cleaner energy supplies.

Figure 1.1 • Power supply trilemma



At present, ASEAN countries are prioritising availability and affordability as their power fuel mix is projected to shift towards coal, which will rise from 32% in 2013 to 50% by 2040. In 2040, 39% of new capacity will be coal. Gas generation will drop from 44% in 2013 to 26% in 2040 as the region runs out of cost-competitive domestic gas surpluses. Up to 2040, only 22% of new additions will be gas-fired. The phasing out of oil from 5.6% of power generation in 2013 to 1.1% in 2040 is mainly due to price concerns, and this trend could be postponed or even reversed if oil prices continue to fall. Hydropower and other variable renewable sources in the ASEAN region are growing and are projected to rise to 22% in 2040.

The ASEAN Plan of Action for Energy Cooperation (APAEC) is intended to enhance energy co-operation by promoting a more diversified power mix and thus strengthening energy security. The APAEC 2016-2020 covers all energy issues and aims at accelerating the implementation of the sectoral action plans listed in Table 1.1. One of the priorities in the APAEC programme areas is the development of the ASEAN Power Grid (APG) interconnection projects. The APAEC also calls for the promotion of clean coal technologies, energy efficiency and conservation, and renewable energy.

<sup>1</sup> The trilemma (also known as the “impossible trinity”) is a theory of international economics which states that, for three given objectives, meeting two goals will necessarily require sacrificing the third. The concept of the trilemma is derived from the Mundell-Fleming model of international macroeconomics.

Table 1.1 • APAEC programme areas

APAEC programme areas		
APG	Trans-ASEAN Gas Pipeline	Coal and clean coal technology
Energy efficiency and conservation	Renewable energy	Regional energy policy and planning
	Civilian nuclear energy	

Source: ASEAN Centre for Energy (2015), website, [www.aseanenergy.org](http://www.aseanenergy.org).

## The APG

The APG started in 1997 as a flagship programme of ASEAN Vision 2020; its aim is to ensure energy security in the ASEAN region through investment in interconnections. The APG aims at ensuring mutually beneficial regional electricity security and sustainability, connecting those countries with surplus power generation capacity to those who face a deficit. A regional grid could help all ASEAN countries meet rising energy demands, improve access to energy services, and minimise the costs of developing energy infrastructure. In addition, the APG could help eliminate inefficient generation, lowering overall costs and making the region more efficient.

At present, however, the APG is a collection of interconnected national grids offering bilateral exchanges of electricity, and is not a unified regional grid. Despite significant increases in power trading since 1990, as shown in Figure 1.2, the nascent APG still consists of a mere 3 453 megawatts (MW) of transmission capacity. The total current installed generation capacity is about 164 gigawatts (GW).

Figure 1.2 • Net electricity imports in ASEAN countries

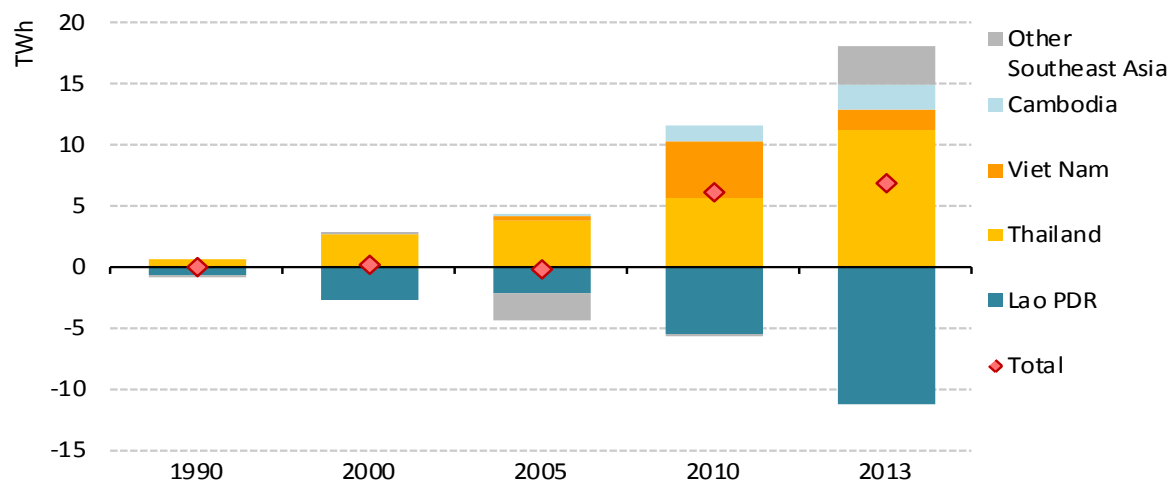

Source: IEA (2015a), World Energy Outlook Special Report 2015: Southeast Energy Outlook, OECD/IEA, Paris.

The most advanced example of power trading is the Greater Mekong Subregion Economic Cooperation Program (GMS). Launched in 1992, GMS includes Cambodia, Lao People's Democratic Republic (hereafter, "Lao PDR"), Myanmar, Thailand, Viet Nam, and extends beyond ASEAN to include a portion of China (Guangxi Zhuang Region and Yunnan Province). As of 2011, there were 11 operational hydropower plants in the GMS and seven under construction, with the majority located in Lao PDR. Trade among GMS members is based on long-term bilateral power purchase agreements signed between utilities and independent power producers (IPPs). Regional integration in the GMS is expected to provide significant economic savings and environmental benefits, and serves as an indication of the possible benefits for ASEAN. The Asian Development Bank (ADB) estimates that the interconnection of GMS power systems has resulted in USD 14.3 billion in savings, coming mainly from the substitution of fossil fuel generation with hydropower.

The APG is moving forward as ASEAN plans to gradually expand interconnections beyond solely bilateral connections – first on a subregional basis and eventually into an integrated ASEAN system. As of May 2015, the planned existing and future interconnections are as shown in Figure 1.3.

**Figure 1.3 • ASEAN Power Grid and the three subregions identified by HAPUA (May 2014)**

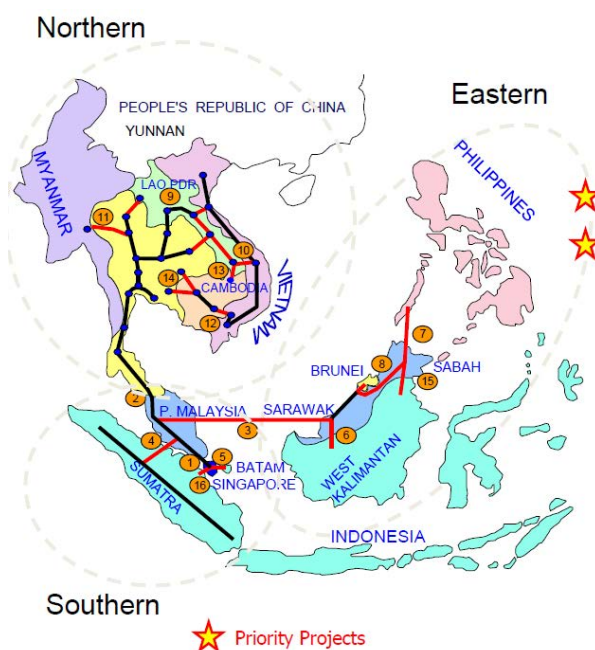

	Earliest COD
1) P.Malaysia - Singapore (New)	Post 2020
2) Thailand - P.Malaysia	Existing
• Sadao - Bukit Keteri	Existing
• Khlong Ngae - Gurun	2016
• Su Ngai Kolok - Rantau Panjang	2016
• Khlong Ngae – Gurun (2nd Phase, 300MW)	
3) Sarawak - P. Malaysia	2025
4) P.Malaysia - Sumatra	2019
5) Batam - Singapore	2020
6) Sarawak - West Kalimantan	2015
7) Philippines - Sabah	2020
8) Sarawak - Sabah – Brunei	2020
• Sarawak – Sabah	Selected
• Sabah – Brunei Not	2016
• Sarawak – Brunei	
9) Thailand - Lao PDR	Existing
• Roi Et 2 - Nam Theun 2	Existing
• Sakon Nakhon 2 – Thakhek – Then Hinboun (Exp.)	2015
• Mae Moh 3 - Nan - Hong Sa	2019
• Udon Thani 3- Nabong (converted to 500KV)	2018
• Ubon Ratchathani 3 – Pakse – Xe Pian Xe Namnoy	2019
• Khon Kaen 4 – Loei 2 – Xayaburi	2015-2023
• Thailand – Lao PDR (New)	
10) Lao PDR - Vietnam 2016-2020 11) Thailand - Myanmar	2018-2026
12) Vietnam - Cambodia (New)	2020
13) Lao PDR - Cambodia	2016
14) Thailand - Cambodia (New)	Post 2020
15) East Sabah - East Kalimantan	Post 2020
16) Singapore – Sumatra	Post 2020

This map is without prejudice to the status of or sovereignty over any territory, to the delimitation of international frontiers and boundaries, and to the name of any territory, city or area.

Source: HAPUA (Heads of ASEAN Power Utilities Authorities) (2015), presentation by HAPUA Secretary at 21st HAPUA Working Group Meetings, Melaka, Malaysia, May 2015.

**Table 1.2 • Planned interconnections until 2020**

Country	Capacity (MW)
<b>Priority interconnections</b>	
Peninsular Malaysia–Sumatra in 2019	1 030
Sarawak–Brunei in 2018	300
Lao PDR–Cambodia in 2018	300
<b>Interconnections planned by 2020</b>	
Thailand–peninsular Malaysia	400
Thailand–Lao PDR	6 447
Lao PDR–Viet Nam	4 399

Source: HAPUA (Heads of ASEAN Power Utilities Authorities) (2015), presentation by HAPUA Secretary at 21st HAPUA Working Group Meetings, Melaka, Malaysia, May 2015.

Figure 1.3 also depicts three subregions as identified by the Heads of ASEAN Power Utilities/Authorities (HAPUA); the northern, eastern, and southern subregions. The northern subregion encompasses Viet Nam, Lao PDR, Myanmar and Thailand while the southern subregion covers Peninsular Malaysia and Sumatra (Indonesia). The Philippines, Borneo Island (including Brunei Darussalam, hereafter, “Brunei”) and Sulawesi (Indonesia) are categorised under the eastern subregion; however, in the foreseeable future, cross-border interconnections between Brunei, West Malaysia and Kalimantan will be more feasible than a long-distance submarine interconnection between the Philippines and Sulawesi Island.

At the 32nd ASEAN Ministers of Energy Meeting (AMEM), ASEAN countries agreed to integrate their power supplies and establish a pilot project to send 100 MW from Lao PDR, through Thailand and Malaysia, to Singapore. The Lao PDR-Singapore pilot project is the first concrete initiative towards further multilateral electricity trade.

By 2025, it is envisioned that there will be up to 22 576 MW of cross-border power exchanges through cross-border interconnections. It is also estimated that the integration of the ASEAN network will result in a net saving of USD 788 million and a reduced installed capacity by 2 013 MW (HAPUA, 2015).

#### **Box 1.1 • Thailand-Lao PDR hydropower interconnection**

The Thailand-Lao PDR hydropower interconnection, established in 1971, is one of the longest-standing electricity interconnections in the region and supports exports of approximately 2 293 MW of electricity from Lao PDR to Thailand via four existing sites. From this connection, Thailand was able to gain access to cheaper electricity fuelled by hydro, whereas its own national resources were previously mainly dependent on oil and gas. In turn, Lao PDR was able to use part of Thailand’s transmission network to provide electrical access to its own remote areas. This is possible under an agreement that Thailand re-exports part of the electricity to Lao PDR, since Lao PDR does not have the infrastructure to provide access to remote border towns. Lao PDR also earns income from the export of electricity. The electricity exchange encourages the strong commercial interest in Thailand’s and Lao PDR’s energy development. In order to further maximise the exchange of electricity, Thailand has acted as a developer of power generation and transmission and development (T&D) projects in Lao PDR. Thailand has served as a long-standing electricity customer to Lao PDR based on memorandum of understanding (MoU) agreements between the two governments and power purchase agreements (PPA). Lao PDR is also currently developing hydropower projects to export to Viet Nam (approximately 1 410 MW between 2015 and 2020) under similar exchange models.

**Box 1.2 • Singapore-Malaysia interconnection and the Austro-Hungarian exchange**

The Singapore-Malaysia interconnection has connected Singapore and southern Malaysia since 1983. Aimed at emergency security and peak demand support, the connection is based on zero net energy exchange on a monthly basis (normally 100 to 200 MW). Power exchanges are netted to zero in order to avoid pricing issues, since each operates very different power markets, and the main intent of the interconnection is to maintain grid stability and provide emergency power. However, the bilateral connection has also aided in establishing bilateral commercial exchange between Singapore and Malaysia. In 2011, Malaysia's Tenaga Nasional Berhad established a commercial exchange deal with Singapore's PowerSeraya for cross-border export of electricity caused by capacity shortages due to lack of adequate gas feedstock supply. To support the promotion of the commercial exchange deal and to secure the deal, Singapore's Energy Market Authority and the Ministry of Trade and Industry provided PowerSeraya with certain exemptions through the Electricity Act.

A similar example from Austria-Hungary's interconnection deal in the 1980s demonstrates how to improve on this arrangement. At the time this was a 3:1 deal to account for differences in costs and differing daily consumption patterns. The Austria-Hungary example demonstrates how to trade/exchange power between two different socio-economic systems and shows that power exchanges do not need to be based on full harmonisation of domestic governance arrangements.

***Challenges for regional power integration***

The APG faces a number of natural and man-made challenges. ASEAN countries vary greatly in their size, political economy, geography and national energy resources. For example, the energy landscape of Indonesia's population of 250 million inhabitants and 17 000 islands differs vastly from that of Lao PDR with 6.6 million people in a landlocked country. Geographically, ASEAN countries are mountainous and in many cases separated by large bodies of water, making some physical interconnections a technical and economic challenge. ASEAN member countries also vary considerably with regard to their power sector regulations, market structure and technical characteristics. Both physical and institutional infrastructures need to be in place for regional energy co-operation to function properly.

***Financing***

Given the challenging geography, funding cross-border connections can be a major hurdle. Power system investment needs are significant compared to the existing ASEAN asset stock and to global investment needs. IEA projections in Figure 1.4 show that the total power sector investments required – excluding interconnections – may reach USD 1 308 billion by 2040. The current APG plan is estimated to cost USD 20 billion. It is evident that public spending is limited and will not suffice for the timely development of the envisaged electricity infrastructure.

The completion of some interconnections is more realistic than that of others because of existing business scenarios. These projects enjoy funding from multilateral development banks, bilateral agencies and the private sector. However, other APG projects lack economic viability although they have regional benefits and can be seen as a regional public good.

ASEAN needs to invest more directly in the APG, provide public guarantees to attract more private and foreign direct investment and avoid funding strategic regional interconnections solely from its own budgetary resources.

Figure 1.4 • Average annual investment in the power sector

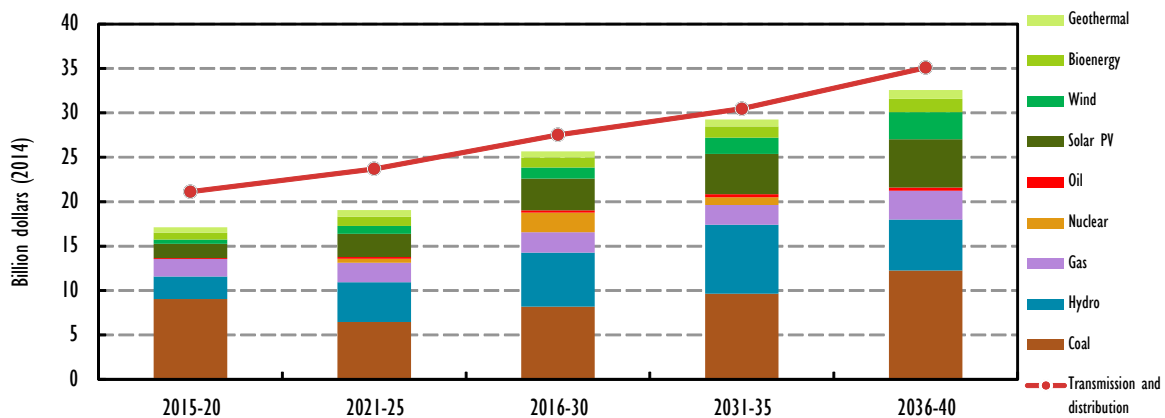

Source: IEA (2015a), *World Energy Outlook Special Report 2015: Southeast Asia Energy Outlook*, OECD/IEA, Paris.

## Governance

Even if funding is available, electricity grid interconnections are complex to develop and manage. In May 2013, a fallen tree knocked out a third of Viet Nam's power supply across 22 provinces and cities. Viet Nam provides Cambodia with about 40% of its national electricity supply and as a result, parts of Cambodia, including the capital city Phnom Penh, lost power supply for more than ten hours. This example underlines the importance of cross-border planning and operations to maintain secure power supply through physically interconnected systems.

Brunei, Cambodia, Lao PDR, and Myanmar have traditional vertically integrated, state-owned power utilities, while Indonesia, Malaysia, Thailand, and Viet Nam have private IPPs operating together with state-owned utilities. Only the Philippines and Singapore have fully "unbundled"<sup>2</sup> power sectors using privatised power generators and independent grid operators. ASEAN's tendency to implement reforms from within a given country rather than between countries has been a major barrier in achieving a single APG. More focus needs to be put on discussing the appropriate governance model for any given interconnection. This includes national regulations on interconnections that hamper their development. Indonesia, for example, has onerous rules to justify an interconnection with another country.

Co-operation in the supply of electricity is heavily affected by differing national regulations and individual country concerns about energy security. Power tariffs and electricity subsidies also differ markedly among ASEAN countries. To date, ASEAN members have implemented regulatory frameworks in a non-integrated fashion. For example, some projects are run as joint venture agreements between state-owned companies. These agreements have faced complications because of differing national regulations. Joint venture companies are also often considered to be foreign-owned, even if part of the company is domestically-based, and thus are subject to conflicting regulations that cause delays. Such trade and investment barriers do not promote a secure investment environment and are not very attractive to private investors.

<sup>2</sup> This study distinguishes five main types of such unbundling: 1) Unified ownership requires no unbundling; both network and generation activities continue to be owned and managed by the same company. 2) Accounting unbundling is the least drastic form of unbundling; separate accounts must be kept for the network activities and generation activities to prevent cross subsidisation. 3) Functional unbundling (also called management unbundling) requires, in addition to keeping separate accounts, that the operational activities and management are separated for transmission and generation activities. 4) Legal unbundling requires that transmission and generation be put in separate legal entities. 5) Ownership unbundling is the most drastic form of unbundling (here referred to as fully "unbundled". Generation and transmission have to be owned by independent entities. These entities are not allowed to hold shares in both activities.



Much of the necessary institutional support for harmonising an ASEAN grid is still in the preparation phase. The establishment of an APG transmission system operators (ATSO) institution and an APG generation and transmission system planning (AGTP) institution, which ASEAN is working on, would help harmonise electricity co-operation.

## Country overviews

The ten countries of ASEAN – Brunei, Cambodia, Indonesia, Lao PDR, Malaysia, Myanmar, Philippines, Singapore, Thailand and Viet Nam – represent a diversity of important electricity issues in Southeast Asia. The inherent differences among ASEAN countries have important implications for the different power systems in terms of markets (pricing, impact of subsidies), governance frameworks (institutions, policies), electricity security (national resources, electrification, emergency), as well as region-wide initiatives, at both individual country and regional levels. With an almost linear trend in population growth and strong economic development, demand growth may soon surpass the available capacity for generation, and these differences will become increasingly important – both as challenges and as opportunities.

**Figure 1.5 • Population growth in ASEAN countries and examples of 15-year historical trend for kWh consumption per capita**

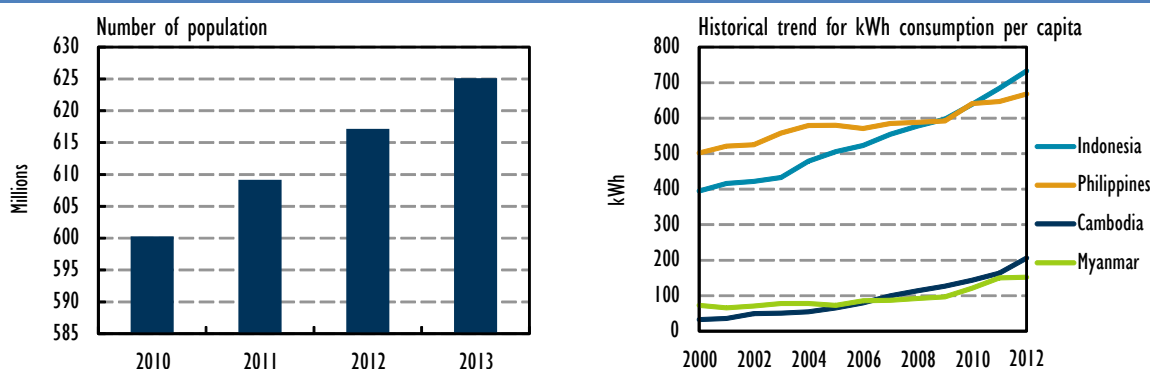

Note: kWh = kilowatt hour.

Source: ASEAN, selected basic ASEAN indicators, as of December 2014, [www.asean.org/resources/2012-02-10-08-47-55/asean-statistics](http://www.asean.org/resources/2012-02-10-08-47-55/asean-statistics); and IEA (2015b), "15-year historical trend for kilowatt hour (kWh) consumption per capita", IEA *Electricity Information* (database), [www.iea.org/statistics/](http://www.iea.org/statistics/).

**Figure 1.6 • Installed capacity in each ASEAN member country**

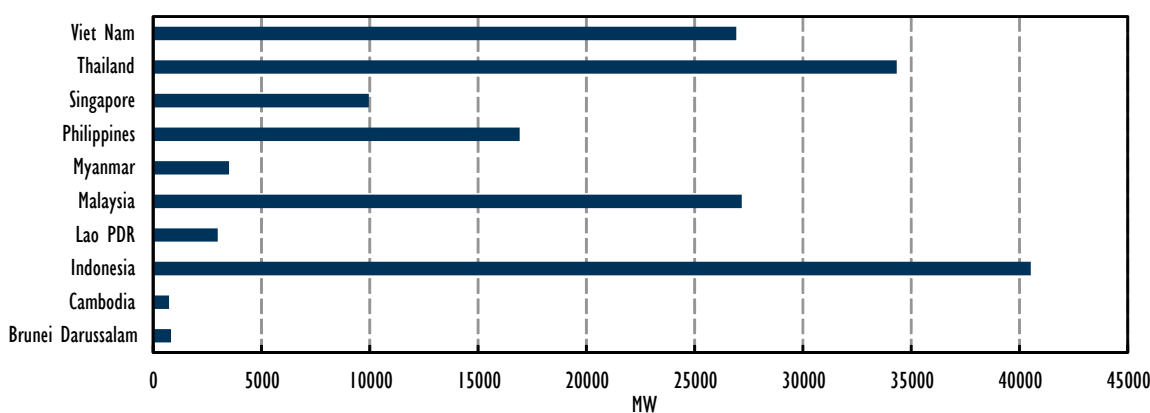

Source: Syaiful, I. (2015), "ASEAN Power Market Integration", presented at ACE-HAPUA-IEA-World Bank Workshop, March 13, Jakarta.

## Brunei

Brunei has an installed capacity of 827 MW. Given its abundance of domestic natural gas, almost all of its installed capacity is gas-fired. In 2011, Brunei had a peak demand of 606.1 MW and a total annual demand of 3 389.5 gigawatt hours (GWh). The country has significant solar, hydro and biomass potential, but operates only one 1.2 MW solar power plant at present. Private entities are not new to the power sector in Brunei. In 2011, the private firm Berakas Power Management Company Sdn. Bhd. (BPMC) supplied 40% of Brunei's power. As of 2014, 99.7% of the general population has access to electricity. Brunei is focusing on strengthening the national grid's subtransmission network and on providing future regional connectivity. Ongoing and future APG interconnection projects with a total capacity of 300 MW will link Brunei to Sabah and Sarawak, Malaysian states located in Borneo. This could reduce Brunei's reliance on domestic gas resources for electricity generation.

## Cambodia

Cambodia's installed capacity totals 732 MW. In 2011, Cambodia had a peak demand of 671 MW and a total annual demand of 3 400 GWh. Cambodia relies heavily on IPP generation, with 91% of generated electric power coming from IPPs in 2011. In 2012, diesel/heavy fuel oil made up 55% of Cambodia's power generation mix. Hydropower comprises a 39% share of generating capacity. Additionally, coal and biomass energy contribute approximately 6% of Cambodia's power mix. An estimated 35% (2012) of Cambodia's general population has access to electricity. Since 2010, Cambodia imports over half of its electricity from neighbouring countries – Thailand, Viet Nam and Lao PDR – through existing interconnections. Cost-effective and reliable electrification of rural Cambodia through renewable energy technologies is a priority for government programmes. Cambodia aims to achieve 70% of household electrification with grid quality electricity by 2030. This can be assisted by establishing significant future interconnections with Thailand (2 200 MW) and Lao PDR (300 MW) in the APG plan. Most importantly, electricity exports could provide export earnings as Cambodia becomes a net electricity exporter.

## Indonesia

Indonesia has an estimated 40 524 MW of installed capacity which in 2012 generated 195.9 terawatt hours (TWh). The country is the biggest electricity consumer in the ASEAN region with a total consumption of approximately 173.9 GWh (2012). In 2011, 88% of its fuel mix came from fossil fuel sources (48% coal-fired, 31% gas-fired, and 13% diesel oil-fired power plants). The remainder is made up of hydroelectric (7%), geothermal (5%) and other renewables (1%). Electrification is a significant challenge for Indonesia as the current national rate of electrification is only 76%. While urban development is high, rural electrification faces a multitude of challenges. The government aims to reach 90% electrification by 2020. Indonesia is focusing on the use of locally available energy sources such as coal-fired generation and its geothermal potential to increase its energy diversity and lessen its dependency on oil. To meet urgent power needs, Indonesia introduced two fast-track programmes for the development of 20 000 MW of power generation. Only approximately half of this new generation is currently on line, with the remaining projects largely delayed or not meeting technical standards. In this context, IPPs are expected to deliver 70% of the new power supply and are poised to help the state-owned PLN in providing more electricity. The West Kalimantan-Sarawak interconnection project has recently been energised while another interconnection with Sabah can strengthen the electricity supply on the East Kalimantan side. The island of Sumatra has been identified as a possible interconnection with Peninsular Malaysia and Batam Island near Singapore. Indonesia could benefit from hydro imports from Malaysia, thus reducing diesel-fired generation and generating export earnings from sales to Singapore.

## Lao PDR

The country's total installed capacity is approximately 2 978 GW, with Electricité du Laos (EDL), the state-owned power utility, owning 20% and 80% owned by IPPs. Annual total demand was approximately 2 174 GWh in 2011. Lao PDR has significant local resources for power generation such as wood fuel, coal, and hydropower which is the most abundant and cost-effective energy resource, accounting for 97% of power generation. The total estimated hydroelectric generation potential stands at 23 GW. Lao PDR has several power co-operation agreements with neighbouring countries, such as Thailand, to meet domestic demand during hydroelectric-supply shortages in the dry season. Revenue from cross-border sales has enabled the financing of domestic projects as well as investment in electrification. EDL is steadily expanding the power grid throughout the country; in 2011, electrification rates reached 78%. Rural electrification has been an important component of achieving national electrification, with the government target set at 90% electrification by 2020. Significant hydropower potential has resulted in the conception of the Lao PDR-Singapore multilateral trading project. In addition, multiple interconnection projects with Thailand, Cambodia and Viet Nam have been planned in the next five to ten years. Regional interconnection could help Lao PDR monetise its hydro resources for export and boost its national economy.

## Malaysia

Malaysia is the third-largest energy consumer among ASEAN countries and benefits from the availability of diverse energy resources in the country including oil, gas, coal and renewable energy. Malaysia is a net exporter of oil and natural gas. In this regard, the government seeks to maintain a five-fuel mix for power generation<sup>3</sup> with coal and gas contributing more than 90%. Malaysia has a significant margin of capacity over demand. Annual total demand was approximately 116 428 GWh in 2012 (3 920 kWh per capita). While production is greater than consumption across Malaysia, Sabah has recently experienced power shortages due to rising demand and an aging fleet of power plants. The electrification rate was 99.4%. The electricity supply industry is in large part vertically integrated and the main electricity utilities are government linked. However, IPPs also supply a portion to the national grid. Malaysia's policies also encourage production of renewable energy by small power generators. The country is currently interconnected with southern Thailand, Singapore and West Kalimantan of Indonesia. As mentioned previously, future interconnections are also feasible with Sumatra and East Kalimantan. Malaysia could benefit by reducing its coal-fired generation in exchange for hydro imports.

## Myanmar

The total installed power generation capacity in Myanmar is 3 494 MW, consisting of approximately 75% hydropower, 21% gas-fired, and 4% coal-fired capacity. In 2012, total electricity production was 10 732 GWh while consumption was 8 021 GWh. Of this, 7 766 GWh was supplied by hydropower while 2 144 GWh came from natural gas turbines. The demand is expected to grow at an annual rate of between 9% and 14%. Myanmar's power sector is based on a state-owned single-buyer model, and electricity remains heavily subsidised. Though IPPs are allowed, low prices have so far deterred IPPs from entering the market, through several foreign companies are interested in investing. Myanmar has the lowest rate of electrification among ASEAN countries; the electrification rate is about 32%. Inefficient power plants and grid efficiency losses burden Myanmar's power system. Myanmar is planning to increase its total installed capacity to 6 823 MW by 2016 by increasing its gas-fired power plants. Electrification efforts can be supported by the realisation of the APG planned interconnection with Thailand. Similarly to Lao PDR and Cambodia, Myanmar could earn foreign exchange by exporting electricity to countries with higher prices and greater demand.

<sup>3</sup> The five fuels are coal, natural gas, oil, hydro, and renewables.

## Philippines

The installed capacity of the Philippines is 16 924 MW and in 2012 peak demand reached 10 216 MW. Total generation amounted to 72.9 TWh while the estimated consumption was 59.2 TWh. The power generation mix is relatively balanced among coal (28%), hydropower (21%) and geothermal (24%). The country is the world's second-largest consumer of geothermal energy and has a high capacity for renewable energy. IPPs play a significant role in the Philippines electricity sector, providing 44% of the total installed electricity capacity in 2012. However, controversial IPP contracts have contributed to the country's extremely high electricity prices. The Philippines consists of over 7 000 islands of which the major islands enjoy near 100% electrification. Overall, 80% of the population have access to electricity and 95% of all communities. The three major grids are all nearing or already at their critical level due to low generating reserve margins and aging generation, and are the reason for rotating blackouts in certain regions since 2011. Given the complex geography, the government faces challenges to achieving its goal of 90% household electrification by 2017. Any interconnection with other countries will require significant investment in submarine cable lines. The nearest and most feasible project would be a connection with Sabah, Malaysia. Although participation of the Philippines in the physical APG will be limited, multilateral co-operation can result in mutual benefits (e.g. grid code harmonisation).

## Singapore

Singapore's installed generation capacity was 9 951 MW and its peak system demand was 6 323 MW in 2013. Given Singapore's mature economy as compared to other ASEAN countries, electricity demand growth is relatively slow. However, Singapore is fully dependent on imported fuel resources for its power generation. Approximately 80% of Singapore's electricity demand is produced from gas-fired generation. Due to limited land area and natural endowments, Singapore is recognised as "alternative energy disadvantaged" under the United Nations Framework Convention on Climate Change (UNFCCC) and diversification of supply has become an important issue. Singapore has a single grid that provides service for 100% of the population. Singapore is also connected to the National Grid of Malaysia by submarine cables, with a transmission capacity of 200 MW. This interconnection can be upgraded in the future, while Batam Island near Singapore may also be interconnected with Sumatra, Indonesia. Singapore employs a wholesale electricity market and is Asia's first liberalised electricity market. The country's experience in this regard may also benefit its ASEAN counterparts given that Singapore could reduce its dependence on imported gas and increase access to generation imports.

## Thailand

Thailand's total installed capacity is approximately 34 335 W. In 2013, Thailand's peak demand was 26 121 MW. Natural gas makes up approximately two-thirds of power generation as domestic oil and coal reserves are very limited. Dependency on gas-fired power generation makes Thailand vulnerable to fluctuations in the international market, and poses important concerns for electricity supply and power security. Thailand's National Power Development plan focuses on increasing green energy to maintain the security and adequacy of the power system. The state-owned generator Electricity Generating Authority of Thailand (EGAT) still dominates 47% of the electricity market share, though it is followed by IPPs which hold 37%. As of 2012, Thailand had an electrification rate of 99.3%. Thailand's electricity imports have tripled in the past decade as demand and grid interconnections expand. In 2012, Thailand imported 10.3 GWh from existing interconnections with Malaysia and Lao PDR. Against this backdrop, Thailand will play a major role in the APG as future interconnections with Lao PDR, Cambodia, Myanmar and Peninsular Malaysia

have the potential to boost security of supply and present the opportunity of additional electricity imports. Increasing import capacity would help Thailand to decrease its gas dependency, decarbonise its electricity sector, and increase access to generation capacity.

## Viet Nam

Page | 20

Viet Nam's total generation capacity stood at 26 926 MW with peak demand at 18 649 MW in 2012. Total generation amounted to 122.8 TWh while estimated consumption was 109.6 TWh. Viet Nam's generation mix is made up as follows: 56% from coal, oil and gas, 35% from hydropower, and approximately 2% from renewable resources. Viet Nam has seen the strongest increase in electricity demand of all ASEAN countries in the past decade. In order to further ensure the security of power supply, Viet Nam plans to develop more than 10 000 MW of nuclear energy by 2030. Viet Nam is actively promoting domestic and foreign IPPs, which accounted for 29% of installed capacity in 2009. Viet Nam has a 99.6% electrification rate as of 2014. The state power company aims to achieve 100% electrification by 2020 by connecting regional grids into one national grid. Viet Nam presently exports electricity to Lao PDR and Cambodia and purchases electricity from China through transmission lines. In the APG, additional interconnections with Lao PDR may enable Viet Nam to import lower-cost hydropower and effectively reduce the country's dependence on fossil fuels. Viet Nam could decrease its reliance on coal and imports and decarbonise its electricity sector.

**Table 1.3 • Selected electricity market integration indicators (estimated)**

Indicator / country	BRN	KHM	IDN	LAO	MYS	MMR	PHL	SGP	THA	VNM
Investments 2035 (USD billion)	20	25	300	15	190	50	163	22	224	100
Subsidies 2012	Yes	Yes	Yes	Yes	Yes	Yes	No	No	Yes	Yes
IPP % 2012	40	91	41	43	47	0	85	100	39	15
Governance (metering, etc.)	Post-paid	Post-paid	Post-paid	Post-paid	Post-paid	Post-paid	Post-paid	Smart meters	Post-paid	Post-paid
Access to %	100	34	76	78	100	32	70	100	99	99

Source: IEA (2013), *World Energy Outlook Special Report 2013: Southeast Asia Energy Outlook*, OECD/IEA, Paris; ERIA (2014), *Investing in Power Grid Interconnection in East Asia*, Jakarta, ERIA; ADB (2013), *Energy Outlook for Asia and the Pacific*, ADB, Manila, Philippines.

The above table demonstrates that ASEAN countries face significant hurdles in creating a fully liberalised regional electricity market. Given the prevalence of subsidies, the absence of modern metering systems and grids in most countries and a need to invest in economically unviable rural electrification from a utility viewpoint, means that the APG would need to start by increasing bi- and multilateral connections of dedicated generation capacity.

As ASEAN currently lacks enforcement, planning, and budgetary powers comparable to the European Commission and subsidiary European regulatory bodies, ASEAN member states need to start creating adequate institutions and look at workable governance models to increase electricity trade across countries. Clearly, this is a long-term agenda for ASEAN, especially considering that it took the European Union more than 50 years to establish the notion of a single market.

## Power sector governance

### Historical development, ownership and investment

Historically, power sectors worldwide have shown similar patterns of development. While the timeline and the detailed arrangements vary across countries, the basic pattern can be described as a co-evolutionary process of technological innovation in generation, distribution and transmission of primary energy endowments, financing of utilities, political movements and the formation of their corresponding regulatory frameworks.

The early evolution of the electricity industry was largely driven by private and often foreign investors (Kessides, 2004). In Indonesia, the private company ANIEM<sup>1</sup> was the first company to generate and sell electricity in Jakarta in 1897 before it was nationalised in the 1950s. Similarly, in the Philippines, the private company, La Electricista de Manila, provided the country's first electricity in 1894. In Thailand, the Danish company Siam Electricity commissioned the Wat Lieb power plant in 1901 to supply Bangkok. Enclave developments of captive power stations established by companies operating in agriculture, mining or the oil business have also played a vital role. The first hydroelectric plant in Malaysia, for example, was built in 1900 by the Raub Australian Gold Mining Company.

Power sectors are characterised by their high capital intensity and raising sufficient capital has always been a major issue. In the early days, foreign direct investment (FDI) in power sectors was often enabled by loans from the international finance community through multinational power companies. Around 1930, electricity utilities in many developed countries had significant shares of foreign (private) ownership; these included Austria (foreign ownership of 20%), Canada (34%), France (10%+), Spain (27%) and the United Kingdom (5-10%). A similar situation prevailed in many developing countries, where there were sometimes dominant levels of foreign ownership; among them were Brazil (67%+), Chile (88%), China (51%+), Indonesia (100%), Malaysia (46%) and Thailand (50%+) (Hausman et al., 2008).

Whereas in the early stages government intervention was restricted to awarding franchises and concessions – often on the municipal level – governments soon began to play an increasingly dominant role in both the regulation and ownership of utilities. When the concession of the Siam Electricity Co. Ltd company<sup>2</sup> expired in 1950, the Thai government took over its operation and in 1958 created the Metropolitan Electricity Authority (MEA). The rise of state-driven development has been fuelled by a complex mix of factors: increasing awareness of critical infrastructures and national security concerns, natural monopoly considerations, decolonisation, nationalisation in communist countries and Keynesian policy movements in non-communist countries. Together, this has resulted in the nationalisation or quasi-nationalisation of the power sector. Since the 1930s (starting in the United States), the power sector in countries around the world has either been entirely state-owned with direct and permanent political control or organised as investor-owned utilities that operate under government-granted and regulated monopolies.

---

<sup>1</sup> The Netherlands Indies General Electricity Company, Algemeene Nederlandsch-Indische Electriciteits-Maatschappij (ANIEM).

<sup>2</sup> Since 1939, it was the Thai Electric Corporation Limited.

## Conventional organisational structures of the power sector

In spite of the vast differences in country characteristics, two basic organisational structures of the power sector have emerged. These are shown in Figure 2.1. In model A, the power sector value chain from generation and transmission all the way to distribution and retail supply is integrated into single, vertically integrated, regional or nationwide electricity utilities. Traditionally, this model has been in place in, among others, France, the United Kingdom and in most Association of Southeast Asian Nations (ASEAN) countries. In the second organisational model B, generation and transmission are separated from distribution and retail supply. This model has been in place in Germany, the United States, Thailand (in all three electricity authorities: Electricity Generating Authority of Thailand [EGAT], Metropolitan Electricity Authority [MEA] and Provincial Electricity Authority [PEA]) and in the Philippines before the reforms of the late 1980s.

Apart from these two fundamental structures, countries have developed different legal and regulatory frameworks in their respective national electricity sectors. Over the decades a wide variety of complex laws, regulations and regulatory and organisational bodies have evolved. Conditions have ranged from great autonomy with largely self-regulating utilities only subject to regulatory tariffs and investment approvals to permanent ministerial control in pricing, staffing, salary and investment decisions. Vertically integrated utilities by and large “produced reasonably satisfactory results” (Kessides, 2004) in most countries during the post-war decades when worldwide electricity demand soared, as they were able to take advantage of economies of scale. Key public policy concerns at that time were the rapid expansion of infrastructures; utilities everywhere were given a mandate to keep pace with the growth in demand by swiftly investing in expansion. Figure 2.1 shows two monopoly models of electricity market. In model (A), the utility is completely vertically integrated, while in model (B), the distribution is handled by one or more separate distribution companies.

**Figure 2.1 • Two monopoly models of electricity market**

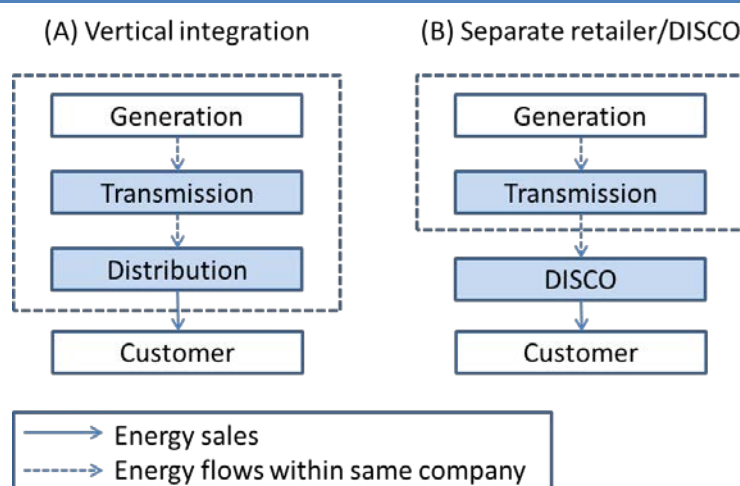

Most of the ASEAN countries experienced rapid growth in the demand for electricity and in response national utilities steadily expanded electricity supply and access through heavy investment. A considerable amount of this expansion was financed by external loans provided by multilateral and/or bilateral aid and concessionary loans.

## Power sector investment costs

Power sector planning requires ASEAN countries to consider long-term investment costs for both generation and transmission. For generation this means evaluating different technologies across multiple criteria, including (but not limited to): the ability to produce power when needed (also referred to as dispatchability); the fuel source; and its environmental impact. For transmission this means careful consideration of system needs, and who should bear which investment costs.

### Generation costs

A key factor in deciding which generation technologies to develop is, clearly, the overall cost of investment. It is therefore useful to have a simplified metric for comparing the cost of generation. One of the most commonly used metrics is the levelised cost of electricity (LCOE).

LCOE is a measure of the cost of a generating technology over its lifetime. Put another way, LCOE is what the generator would have to earn, on a per kilowatt hour (kWh) basis, in order to recover all its fixed and variable costs, assuming zero profit. The LCOE metric is particularly useful in the vertically integrated markets prevalent in ASEAN, where cost recovery is mostly through long-term power purchase agreements (PPAs) and rate-regulated tariffs.

The utility of LCOE is limited somewhat by the fact that it requires making a set of simplifying assumptions. For example, to calculate the amount of electricity produced, it is necessary to assume some average load factor – that is, how many hours per year the plant is expected to run. The LCOE calculation is usually performed assuming ideal conditions, and so load factor assumptions tend to be at the high end of what is realistic. A typical LCOE calculation for a natural gas plant may assume a load factor of 85% or more. In reality, a plant's operation is mostly determined by the system's merit order. The resulting generation mix does not necessarily reflect the capacity mix (Figure 2.2). Additionally, over the course of the plant's operating life, many events can have an impact on its actual operations. An increase in natural gas prices relative to coal, for example, may make it cheaper to shift away from a natural gas-fired power plant to a coal-fired plant. An unexpected decrease in demand may reduce the need to run the plant as often. In either case, over time, the actual load factor of the plant would also be reduced. Similarly, the estimated expected availability and efficiency of the plant may differ over its actual lifetime.

Figure 2.2 • Installed capacity and generation mix for Indonesia in 2013

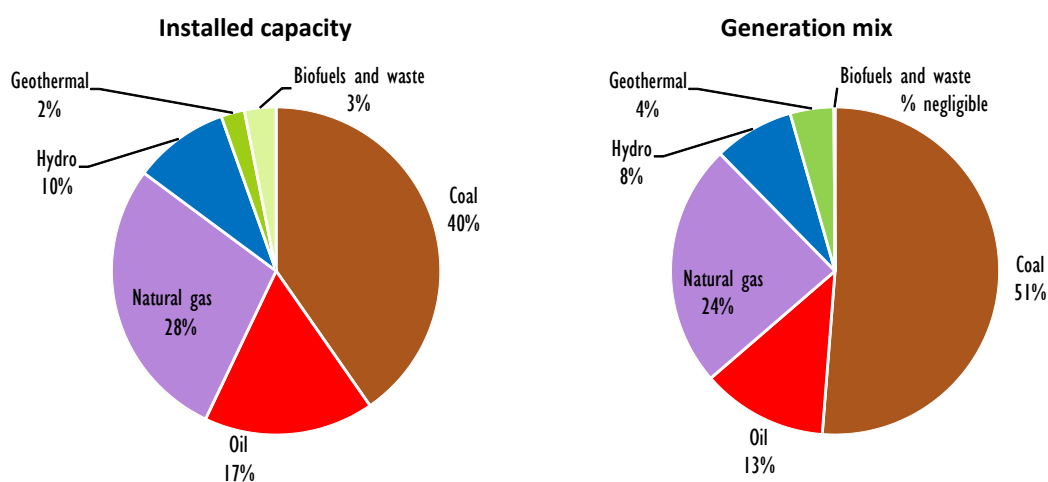

Source: IEA (2015a), *World Energy Outlook Special Report 2015: Southeast Asia Energy Outlook*, OECD/IEA, Paris.



The LCOE for a generating technology in a particular country is heavily dependent on local conditions. Even for technologies that are relatively standardised, the actual cost of development may vary significantly depending on local labour costs, regulations, fuel costs and other factors. Nevertheless, certain aspects of generation cost are relatively consistent across technology types, and can therefore be described in general terms. In particular, regardless of the calculated LCOE, the ratio of capital expenditure (CAPEX) and operating expenditure (OPEX) for different technologies, and the sensitivity of the LCOE to variations in inputs, are relatively predictable.<sup>3</sup>

Figure 2.3 shows the proportion of the LCOE that comes from CAPEX and from OPEX for various technologies. For fossil-based technologies such as combined cycle gasification turbines (CCGTs) and coal-fired plants, CAPEX makes up a relatively small portion of the investment cost as compared to the OPEX. For renewable and nuclear technologies the opposite is the case. The major difference is in fuel costs. For both coal- and natural gas-fired generation, fuel costs make up a large portion of the OPEX, while for nuclear generators these costs are relatively low, and for wind and solar photovoltaic (PV) systems they are entirely absent.

**Figure 2.3 • Proportion of CAPEX and OPEX in LCOE for various technologies**

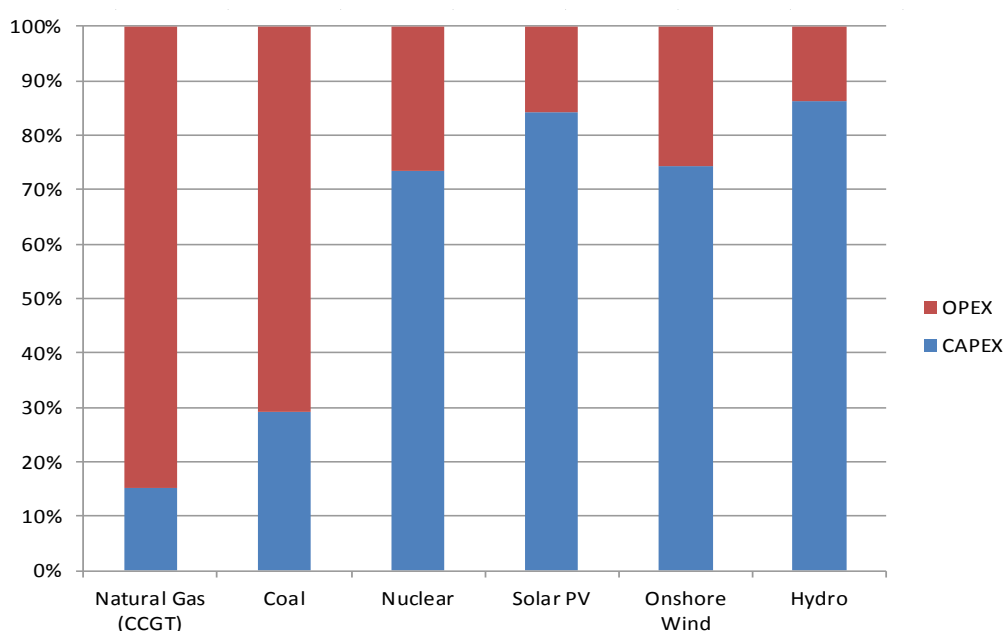

Source: IEA/NEA (2015), *Projected Costs of Generating Electricity 2015*, IEA/NEA, Paris.

As noted above, a number of factors influence the LCOE value for a particular generator, including capital cost, fuel costs (for those technologies that consume fuel), the cost of emissions, the lifetime of the generator and the amount of electricity expected to be generated over its lifetime. Each technology is sensitive to these inputs to varying degrees, which is why looking only at the final LCOE figure and ignoring the underlying assumptions can be misleading.

To illustrate this point, the following figures show the sensitivity of LCOE to changes in a single underlying assumption. For this analysis, we focus on two inputs: discount rate (or the cost of capital) and fuel cost.

<sup>3</sup> A generator's CAPEX includes pre-development, construction and infrastructure costs; while the OPEX include the fixed and variable operational costs, the connection cost, decommissioning fund, heat revenues (for plants that sell heat as well as power), fuel prices, insurance, and emissions costs. Other parameters and assumptions needed to calculate LCOE are the capacity of plant, its expected availability and efficiency, and the expected load factor.

The discount rate – which can be thought of as a proxy for the cost of capital – is of particular importance to technologies that are relatively capital-intensive. The appropriate discount rate is highly dependent on the type of generator, where it is being built, and who the investor is. For example, the LCOE of a nuclear plant being built in a heavily regulated environment with government subsidies would be calculated with a lower discount rate than that same plant being built in a liberalised electricity market without subsidies.

Figure 2.4 shows the variation in LCOE as the discount rate is changed. Nuclear generators are the most sensitive to variations in the discount rate, due to a combination of both upfront investment costs and long construction times (which can be seven years or longer). Doubling the discount rate from 7% to 14% nearly doubles the LCOE of a typical nuclear plant. Solar PV has a relatively short construction time, with most plants operational within a year of start of construction. Nevertheless, it is also very sensitive to changes in the discount rate, mainly due to a combination of relatively high capital costs and a short lifespan (a solar PV plant may last 20 years, while the typical lifespan of a nuclear plant is 60 years).

**Figure 2.4 • LCOE as a function of discount rate**

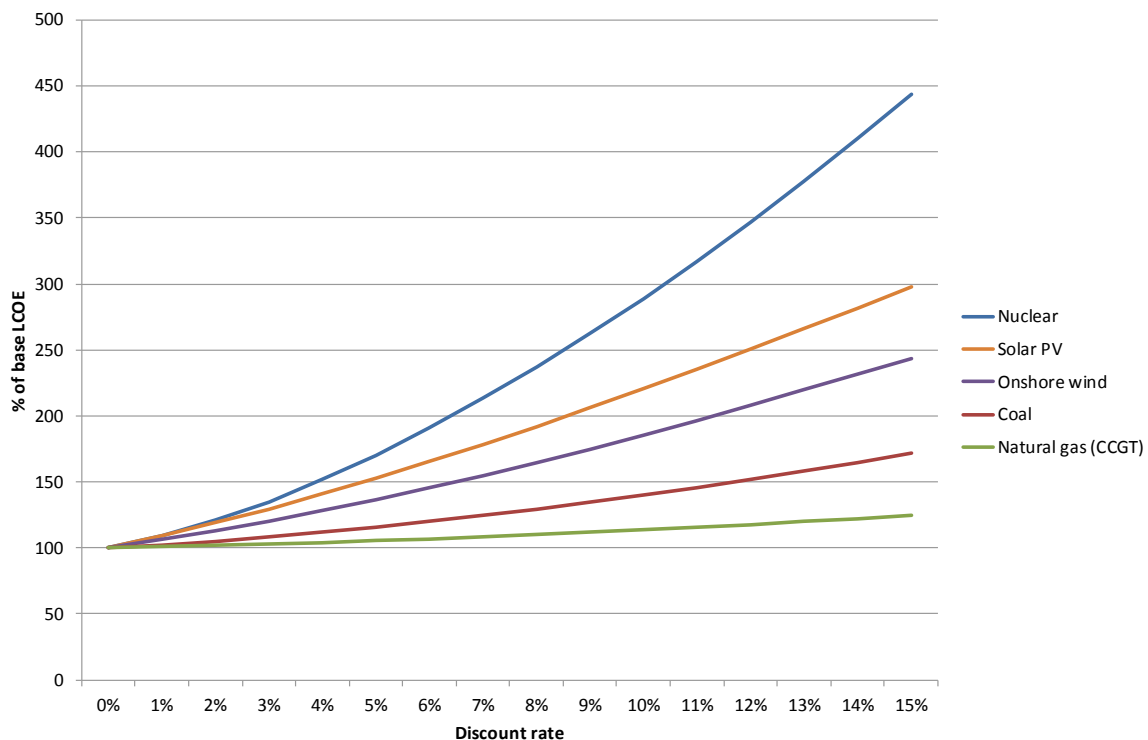

Source: IEA/NEA (2015), *Projected Costs of Generating Electricity 2015*, IEA/NEA.

Coal and natural gas plants, on the other hand, are relatively insensitive to changes in the discount rate. The LCOE of a hypothetical natural gas plant, for example, increases by only 14% when the discount rate is doubled from 7% to 14%. For this reason, both technologies tend to be popular choices in environments where the cost of capital is relatively high.

Natural gas and coal generators are very sensitive to fluctuations in fuel price. Figure 2.5 shows the relative sensitivity of natural gas, coal and nuclear generation to an increase or decrease in the fuel price of up to 50%. Here we see the opposite situation as in the two charts above.

Figure 2.5 • LCOE as a function of fuel cost (7% discount rate)

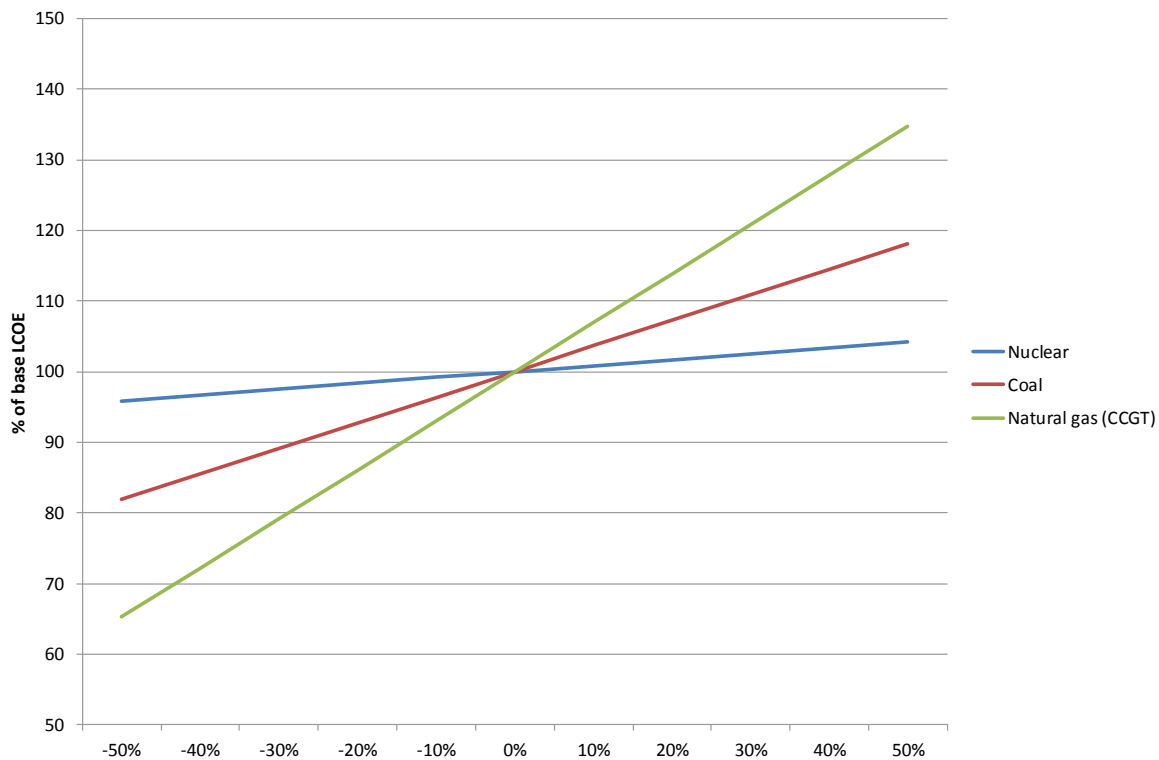

Source: IEA/NEA (2015), *Projected Costs of Generating Electricity 2015*, IEA/NEA, Paris.

Nuclear generators are quite insensitive to changes in fuel price, while natural gas generators are extremely sensitive. A 50% increase in natural gas prices increases the LCOE by more than 30%. Notably, changes in fuel cost have a linear impact on LCOE, because in the LCOE calculation the fuel cost is applied equally in every hour of generation. This is another limitation of the LCOE calculation which, in its simplified form, does not reflect the potential for fuel price variation within the lifetime of a generator.

One important point to be drawn from this chart is that there are potentially significant gains from improving the efficiency of fossil-fuelled generation. Plants that run at higher efficiencies are able to produce more electricity for a given amount of fuel, and so are less sensitive to fuel price fluctuations. The typical coal plant in the ASEAN region is significantly less efficient than coal plants in Japan (Figure 2.6). While the expectation is that the average efficiency of the ASEAN coal fleet will increase, it would be worth examining the degree to which further efficiency improvements would reduce the influence of fuel price volatility on generating costs in the region.

The cost of generation is an important component of electricity tariff formation. Therefore, all technologies and aspects have to be considered in a comprehensive and integrated manner to support least-cost power systems and ensure overall efficacy. In addition, renewable energy may play a more important role in the future as, depending on the geographical factors and available incentives, the cost may be lower than expected.

Figure 2.6 • Comparison of coal-fired electricity generation by technology and average efficiency

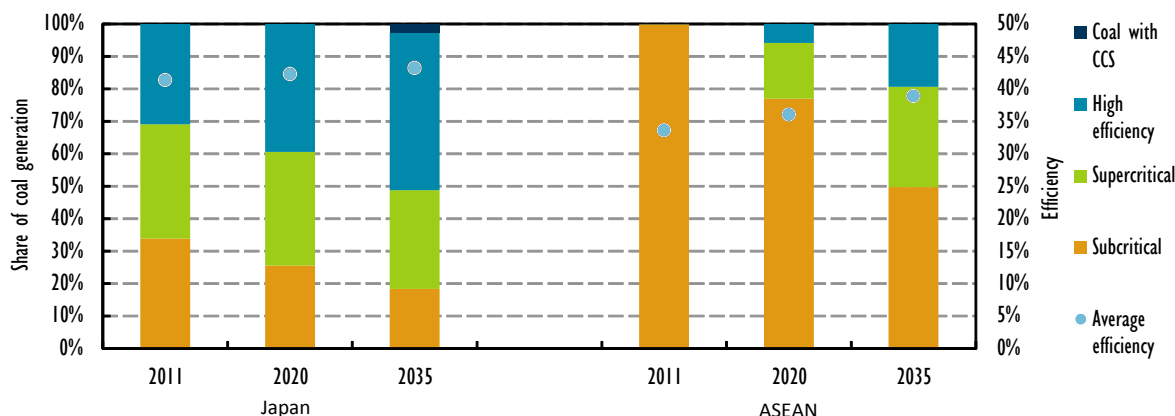

Notes: High efficiency = plants using ultra-supercritical, integrated gasification combined-cycle and combined heat and power technologies; coal with CCS = plants fitted with carbon capture and storage.

Source: IEA (2013), *World Energy Outlook Special Report: Southeast Asia Energy Outlook 2013*, OECD/IEA, Paris.

### Network services

The second cost pillar, after the cost of generation, is the electrical network. As with generation costs, network costs can be divided into fixed and variable costs. Most of the fixed costs consist of capital costs for physical assets like power lines, transformers, etc. Generally, consumers are charged only for the grids they make use of for their electricity supply (Figure 2.7). Besides the grid at the voltage level they are connected to, this also includes all grids in the voltage levels above their power connection. Large industries or railway operators, for example, would not be charged for the costs of medium or low voltage power grids. Households and small industries, however, would be charged pro rata the costs for the grids in all voltage levels (besides low voltage grids also medium, high, and extra-high voltage) because their electricity supply requires the existence of the entire network.

Figure 2.7 • Schematic structure of the power grid

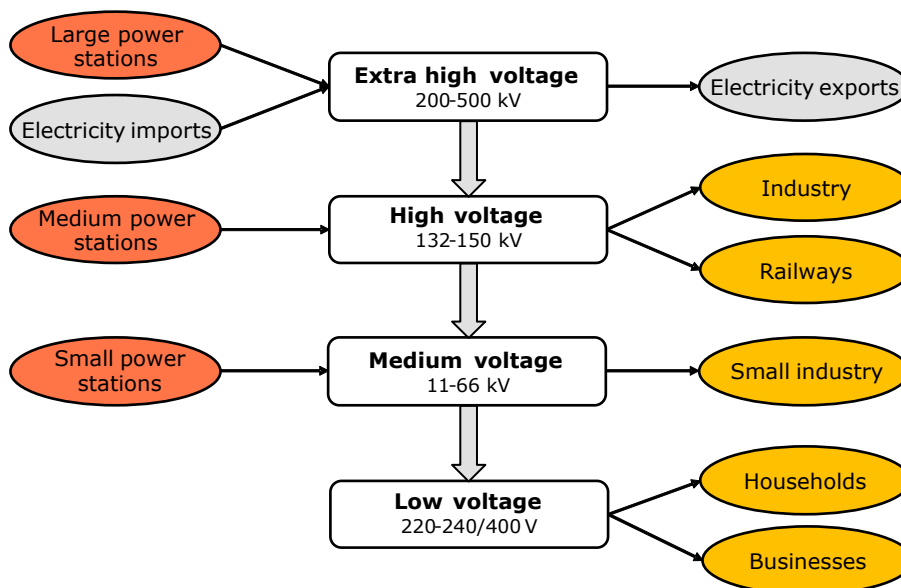

Note: kV = kilovolt; V = volt.

Source: Praktinjo, A. (2013), *Energy Supply Security* (in German), Springer-Verlag.

Variable costs consist mainly of operating and maintenance costs, and also include power losses. Additionally, grid operators might deliver more services aimed at maintaining the stability of the system. In case of unbundled markets, the delivery of these services might be the responsibility of the transmission grid operators as transmission system operators (TSO) or the responsibility of independent system operators (ISO). With such network services, TSOs or ISOs ensure reliable operation of the power grids and avoid blackouts or damage to infrastructure. The cost of these services might add to the existing variable costs. The most important network services are:

- the provision of control power to balance supply and demand in order to keep the grid frequency stable (at 50 Hz or 60 Hz)
- providing reactive power to keep the voltages stable to prevent damage to the electric devices
- organising generation capacities which are sufficiently capable of black starting the power grid after blackouts
- managing power line congestion which might hinder the trading of power within the borders of a market region using redispatches.

An inherent property of power grids is that the relation between fixed and variable costs is very uneven. The fixed costs of power networks (CAPEX) are much higher compared to the variable costs (losses and network services), leading to very high economies of scale. It is therefore unattractive for potential competitors to invest in parallel networks. This is why power grids are considered to be a natural monopoly (unlike power generation or power retail). Liberalisation of power grids would not lead to competition in this field and will not be beneficial in itself in the ASEAN context.

Given these particular characteristics of power grids, the optimal pricing of network services is no easy task. From an economic perspective, network tariffs priced at marginal costs would be the first best solution. However, prices at marginal costs would lead to contribution margins that are insufficient to cover the high fixed costs of power grids. A second best solution would be a network tariff which allows the grid operator to recover all costs and make an appropriate profit. Another option would be two-part tariffs consisting of a commodity charge equal to marginal costs and a capacity charge equal to the difference between average and marginal costs.

### **Price regulation**

Since power grids represent a natural monopoly in the value chain of electricity supply, from a regulatory perspective it is of utmost importance to ensure that this monopolistic position is not misused to exert market power on other stages of the value chain such as generation or retail, e.g. through a discrimination of grid access. In liberalised and competitive market environments, the mechanism of supply and demand will automatically result in efficient power prices as no single producer is able to influence energy prices. In such situations, it is the task of the regulator to ensure that the market remains competitive by preventing the formation of cartels.

However, in case of vertically integrated systems, the regulators need to play a central role to ensure that the monopolistic position is not misused. Several practices exist to regulate prices for monopolistic structures using incentive regulation:

- Cost-plus regulation

The operators are granted a fixed mark-up on the costs (e.g. a fixed rate of return). The operators, however, have no incentive to operate efficiently. Moreover, they are incentivised to increase costs (e.g. with unnecessary investments) because they can pass the costs on to their customers and receive additional profits because of the regulative system.

- Price-cap regulation

The regulator sets a maximum price. In this case, the operators have incentives to delay important investments in order to maximise profits. Under-investment is a significant risk of the price-cap regulation. This poses a threat to security of supply in the long term.

- Revenue-cap regulation

In contrast to the price-cap regulation, the regulator defines a maximal revenue (price multiplied with quantity) for each operator instead of the price in the revenue-cap regulation. In this case, however, the operators might be incentivised to minimise their services in order to increase their profit through saved costs.

### Electricity tariff setting

A discussion of the particular tariffs of each of the ASEAN countries would require detailed analysis that is beyond the scope of this study, in particular considering the important levels of electricity subsidies. However, experiences in ASEAN and elsewhere point to general best practices in tariff setting that should offer valuable lessons to all the countries in question.

Electricity prices for final consumers generally consist of the following components:

- generation costs
- network costs
- retail costs
- taxes and levies (potentially including support for renewables) or subsidies
- profits.

As an example, Figure 2.8 shows the electricity tariff components for Singapore. The market and regulatory system should ensure that all these components can be covered in full. If tariffs are insufficient to recover all costs, the resulting revenue shortfall would need to be recovered through other means, such as through general tax revenues.

**Figure 2.8 • Electricity tariff components for Singapore**

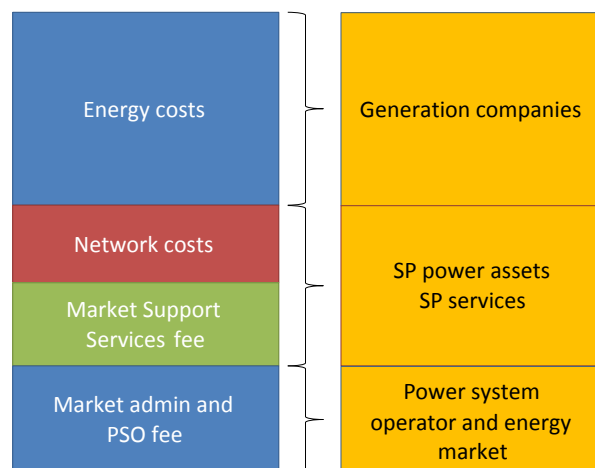

Source: Singapore Government (2015), "Energy Market Authority", website, [www.ema.gov.sg](http://www.ema.gov.sg).

The value of electricity, and thus also the wholesale price, are dynamic over time. The reason for this lies in the non-storability of electricity and the consequential variability of generation and network costs over time. Time variable pricing means the price of electricity would vary to reflect the fact that the cost to supply electricity changes over time.

## The restructured market model

During the 1970s and early 1980s a complex set of political, financial and technical factors converged and triggered a worldwide trend to gradually move away from these traditional, monopolistic vertically integrated arrangements. In the United States, the Public Utility Regulatory Policies Act (PURPA), adopted in 1978, opened the generation market for independent power producers (IPPs). PURPA gave utilities the power to buy electricity from so-called “qualified facilities”, which were mainly co-generators and small power producers. This model became known as the single-buyer model.<sup>4</sup> In single-buyer arrangements the utility remains vertically integrated, but it enters into PPAs with IPPs. A variant is where a power sector has separate or unbundled generation companies, transmission companies and distribution companies, and where the central transmission dispatch company purchases all wholesale power (Hunt, 2002).

The single-buyer model introduces a limited form of competition in power sectors by allowing IPPs to compete to build and operate power plants. However, a defining feature is that IPPs may only sell to existing utilities, which usually remain vertically integrated (Hunt, 2002). In this way, the single-buyer model provides the opportunity to tap outside investors and capital without major structural changes to the sector. In order to attract private IPPs, the utility or another issuing agency such as the regulator has to provide long-term PPAs, which ensure the economic viability of potential projects but simultaneously protect consumer interests. The design of PPA regimes is therefore a central concern in single-buyer models.

**Figure 2.9 • Single-buyer model of electricity market based on vertically integrated version (A) and unbundled version (B)**

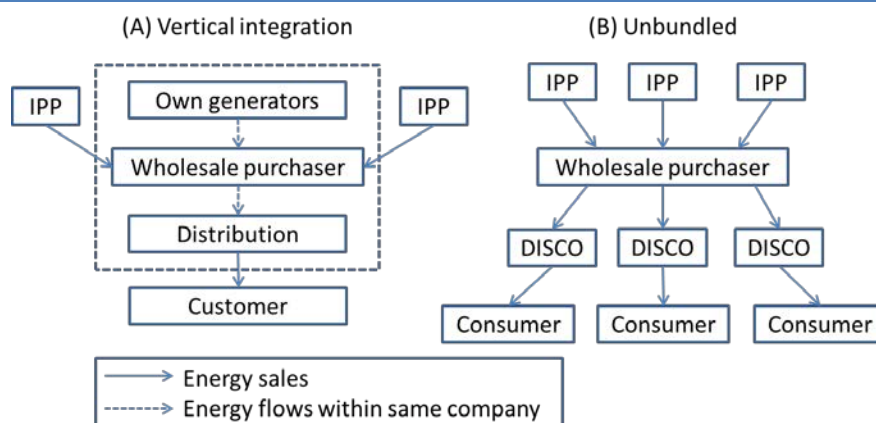

Reform efforts going beyond the single-buyer model were first implemented in Chile with the Electricity Act of 1982. This act led to vertical and horizontal unbundling of generation, transmission and distribution, commercialisation and eventually to privatisation of the existing state-owned electricity system. Later the United Kingdom (1989), Norway (1991), part of the United States (1992), the European Union (1996) and many others undertook reform activities. While reforms varied in their pace and sequence of steps, they followed in most cases what has

<sup>4</sup> Hunt notes that opening the market of the power sector to IPPs was not the major objective of PURPA; it was rather intended to encourage environment-friendly generation of electricity.

been called the “standard textbook model” (Joskow, 2008; Hunt, 2002; Jamasb and Pollit, 2005) which included, among others, the following elements:

- **Electricity legislation, commercialisation and corporatisation:** As a first step, countries must provide sound legal fundamentals. This should involve the corporatisation and commercialisation of utilities. Commercialisation transforms state-owned utilities into separate (from the ministry/government) legal entities with all associated rights and duties such as management structures, hard budget constraints, borrowing, procurement, staffing, payment of taxes and dividends. Corporatisation should accompany commercialisation, which involves cost recovery in pricing and financial transparency through the adoption of (internationally) recognised accounting standards, including explicit accounting of potential subsidies.
- **Vertical unbundling:** This includes functional decomposition of the electricity supply chain into competitive segments (wholesale generation and retail supply) and natural monopoly segments (transmission and distribution). Natural monopoly segments must still be regulated as these constitute monopolistic bottlenecks or essential facilities which are absolutely necessary to provide electricity to final customers. The four most common forms of unbundling are (1) account unbundling with separate accounts for network and generation activities; (2) management unbundling, which requires, in addition to separated accounts, separate management for generation and network activities; (3) legal unbundling which requires separate legal entities for generation and networks; and (4) ownership unbundling where generation and network activities have to be owned by separate entities with no shares in either activity. Among these four forms, account unbundling is the least drastic form of unbundling, whereas ownership separation is the strictest form.
- **The establishment of an independent regulator:** The duty of the regulator is to bring economic efficiency, transparency and a level playing field to the electricity sector by ensuring non-discriminatory access to essential facilities – transmission and distribution networks – for generators and suppliers in order to ensure fair competition, and through it, fair and efficient rate regulation.
- **Establishing wholesale and retail markets:** Regulated prices are replaced with market prices in the respective competitive industry segments. Market designs need to take into account the specific nature and condition of the electricity system which include various issues, among them technical (non-storability, continuous physical balance, etc.), economic (e.g. capital intensity, long lead times), and institutional which are associated with pricing, contracts, scheduling, balancing and network constraints (Hogan, 1998). The marketplace ranges from near-instantaneous markets, to day-ahead hourly spot markets to future and forward markets trading electricity several years ahead.
- **Privatisation:** As a final step, utilities are sold to private investors, and direct government control is completely removed.

Figure 2.10 provides an overview of the pace of developments across Organisation for Economic Co-operation and Development (OECD) member countries measured by five indicators, all scaled between 0 and 6. The individual OECD country scores have been aggregated by simple averaging. The respective indicators and their meaning are as follows:

- **Public ownership** measures the direct or indirect share of government ownership in the largest firm in the electricity sector. A score of 6 implies the firm is 100% under the control of the government, whereas a score of 0 implies no government involvement.<sup>5</sup>

<sup>5</sup> The score is calculated as: percentage of shares owned by government/100 \* 6.



- **Market entry** regulation is assessed based on three equally weighted sub-questions:
  - Third-party access (TPA) to the transmission grid (score 6 = no TPA; 3 = negotiated TPA and 0 = regulated TPA).
  - The existence of a liberalised wholesale market for electricity (yes = 0; no = 6).
  - Minimum consumption threshold that consumers must exceed in order to be able to choose their electricity supplier (score 6 = no consumer choice, lower scores indicate the level of minimum consumption<sup>6</sup>).
- **Market structure** is used as an indicator for market concentration and values the market share of the largest company in the electricity sector (smaller than 50% = 0; 50-90% = 3; greater than 90% = 6).
- **Vertical Integration** assigns a score of 6 if unbundling has not been carried out at all, a score of 4.5 for account unbundling, a score of 3 for legal unbundling and a score of zero for ownership unbundling.
- **Aggregate indicator** is composed of the simple average of the indicators described above. The indicator is scaled between 0 and 6, with the highest score of 6 meaning that the sector has been hardly liberalised.

Generally, a value of 6 implies old, vertically integrated and foreclosed market structures, whereas zero implies fully deregulated and liberalised market structures. As demonstrated in Figure 2.10, at the beginning of the 1990s deregulation across OECD countries gained momentum.

Figure 2.10 • OECD electricity sector regulation indicators (OECD NMR database)

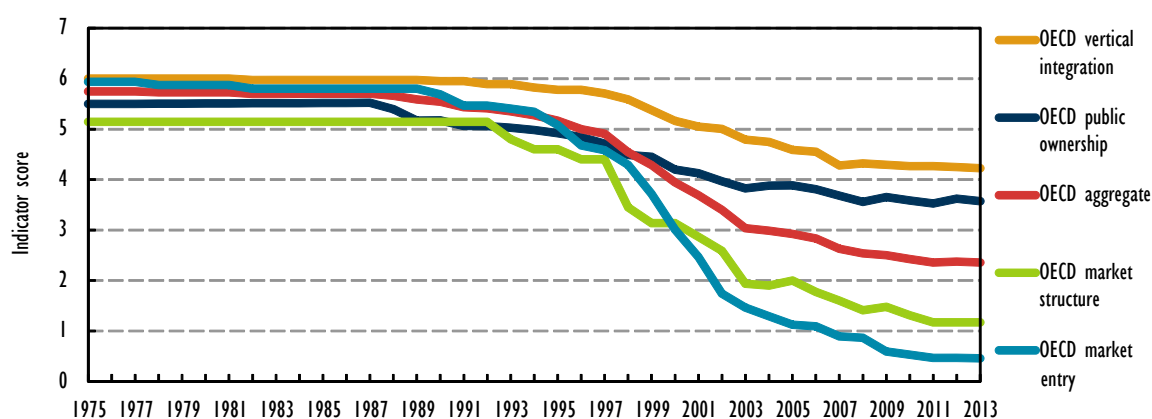

Source: IEA (2015b), "Indicators of product market regulation", "Sector regulators", *Electricity Database*, accessed February 2015, [www.oecd.org/eco/growth/indicatorsofproductmarketregulationhomepage.htm#indicators](http://www.oecd.org/eco/growth/indicatorsofproductmarketregulationhomepage.htm#indicators).

For example, the score of market entry regulation quickly declines, which implies that OECD countries rapidly introduced some combination of competitive wholesale electricity market, TPA, and retail choice. Along with transformations in market entry regulation, the market structure has also changed significantly and the market share of the largest companies in the electricity sector has fallen below 50% in most countries. On the other hand, a certain degree of public ownership is still present in many OECD countries. The same holds true for the degree of vertical integration and the adoption of weaker forms of unbundling. The aggregate average score across all indicators and OECD countries suggests that OECD countries are roughly halfway there.

<sup>6</sup> No minimum consumption threshold = 0; threshold below 250 gigawatt hours per year (GWh/year) = 1; threshold between 250 and 499 GWh/year = 2; threshold between 500 and 999 GWh/year = 3 and threshold above or equal to 1 000 GWh/year = 4.

However, these numbers are only indicative and do not replace detailed country analyses. Similar reform steps may have different impacts in different countries and a reform blueprint for a specific country cannot easily be transferred to another one with similar results.

## Reform efforts in the ASEAN countries

The first reform efforts in ASEAN countries emerged in the late 1980s and the early 1990s. ASEAN countries gradually opened their power sectors to private (and foreign) investors by reforming their respective regulation frameworks to allow for IPPs and often planned to subsequently implement further reform steps from the “standard textbook model”. However, electricity reform activities in most ASEAN countries were fundamentally different from deregulation in OECD countries with respect to motivations, sector conditions and the broader economic context. Electricity deregulation in OECD countries has been motivated by stagnating demand growth, overcapacity and the idea of increasing economic sector efficiency by introducing competition. In contrast, the key concern in most ASEAN countries has been to raise adequate capital for investment in power sector expansion in order to keep pace with the rapid growth in electricity demand.

The ASEAN countries saw exceptional economic growth in the second half of the 1980s, with some countries seeing double-digit average annual real GDP growth rates. Much of this growth was driven by extensive public spending programmes, which, in turn, pushed ASEAN country governments to significant levels of debt. Governments were increasingly unable to finance the massive investments in power sectors required to meet ever increasing demand for electricity. Besides these endogenous developments, sector reform towards liberalisation was strongly encouraged by international and regional financial institutions (Jamasp et al., 2014) that were pushing for competition with private participation in electricity sectors.

In 1987, the Philippines became the first ASEAN country to allow the participation of IPPs with its Executive Order 215, which was modelled after PURPA in the United States. Soon, other countries followed and the market for domestic and foreign IPPs spread across ASEAN countries. As shown in Figure 2.11, investments concentrated on the Philippines, Malaysia, Indonesia and Thailand in the first instance. Most of these investments were “greenfield” projects in power generation. Compared to greenfield projects, divestiture and concessions only played a minor role and were most significant in the Philippines (see Figure 2.4). Significant investments in Cambodia, Myanmar and in Lao People’s Democratic Republic (“Lao PDR”) started only from 2005 onward.

**Figure 2.11 • Private investment in ASEAN electricity sectors between 1990 and 2013**

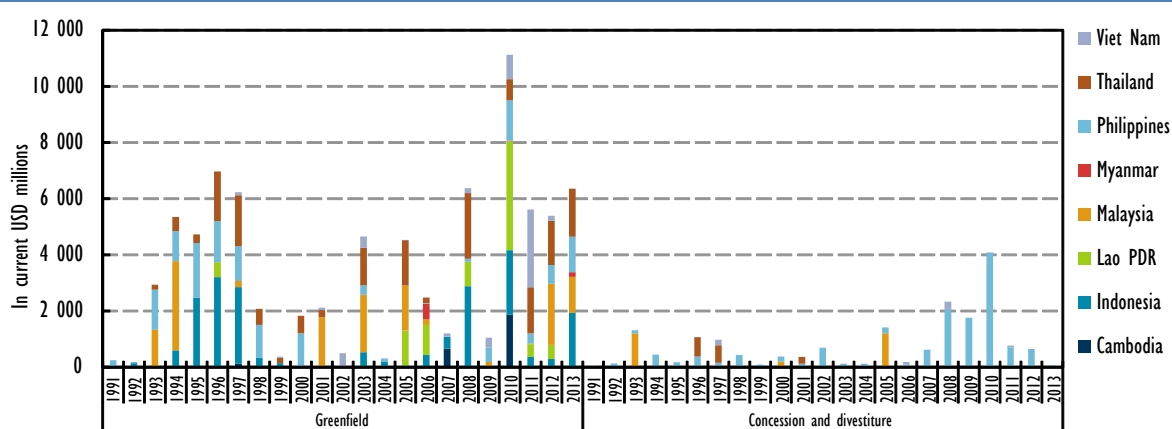

Note: includes generation, transmission, and distribution.

Source: World Bank (2015), *Private Participation in Infrastructure* (database), <http://ppi.worldbank.org/index.aspx> (accessed 9 May 2015).

While the attraction of private investors in the form of IPPs during the 1990s to ASEAN power sectors was initially considered a success, it later became apparent that governance failures, insufficient regulatory settings and a lack of regulatory oversight, combined with the consequences of the Asian financial crisis, resulted in a failure of many IPPs<sup>7</sup>. It was expected that IPPs would not only relieve governments' budgets of the financial burden of power sector investment, but also promote competition, resulting in higher power sector efficiencies and lower rates for consumers (World Bank, 1993).

However, these gains can only be achieved if the appropriate regulatory environment is in place. In many ASEAN countries this was not the case. For IPPs, ASEAN countries were highly attractive because of the generous terms provided by both ASEAN governments and utilities. Typically, PPAs were designed to minimise the risk borne by IPPs at the expense of their counterparts. Governments and domestic utilities had to bear the risks associated with market demand, exchange rates, fuel costs, retail tariffs and sovereign risks. From the investor's perspective IPPs were virtually risk-free.

Certain lessons have emerged from the experience with IPPs and PPAs in ASEAN and elsewhere. Competitive bidding regimes have been demonstrated to be the most cost-effective method for IPP and PPA procurement. Direct negotiations are the least cost-effective and should be avoided whenever possible. IPP procurement design is a major conceptual issue not only in single-buyer arrangements, but also in sophisticated long-range planning. With "bankable" PPAs that provide sufficient financial assurance to IPPs, in principle, any power plant project can be realised. The key challenge, however, is to embed the IPP procurement decision into a planning process, which encompasses comprehensive evaluation of a wide range of alternatives so as to identify the very best projects. Integrated resource planning (IRP) such as that implemented in several US states provides a good framework for realising prudent planning. IRP involves an assessment of a variety of alternatives, including, among others, life extension or performance enhancement of existing capacity; demand-response and energy efficiency; reliance on mobile, flexible or temporary power sources; transmission enhancement; cross-border connections, renewables or various combinations of these (RAP, 2013).

In principle, IRP can be conducted by the utility, but should always be subjected to extensive regulatory review and should include a transparent stakeholder consultation process. The IRP process is demanding and requires defining and constant updating of a wide range of input factors,<sup>7</sup> the application of state-of-the-art planning tools<sup>8</sup> and sensitivity assessments,<sup>9</sup> as well as an open discussion and inclusive decision-making process on these aspects with all relevant stakeholders.<sup>10</sup> In order to achieve efficient and satisfactory regulatory review and approval, regulators must be given corresponding endowments in terms of qualified staff, budgets, and statutory authority (see Box 2.1 below).

---

<sup>7</sup> Including (peak) demand growth forecast, load curve developments, reserve margin requirements, generation plant lead-time, flexibility, dispatchability and reliable availability at peak, fuel-availability, costs of available generation technologies, techno-economically available potential of demand-side resources and spatial system characteristics including demand and generation location and network capacity availabilities.

<sup>8</sup> To assess (peak) demand developments as well as the optimal techno-economical supply and demand mix in a multi-generation technology system.

<sup>9</sup> To identify probabilities regarding techno-economical supply and demand mix.

<sup>10</sup> To gather a maximum amount of input, strengthen input factors and stakeholder confidence in the results.

**Box 2.1 • IRP as an alternative to power development plans**

It can be very useful to move upstream in the power sector planning process and focus on the stage at which power development plans (PDPs) are being made. Conventional PDPs only consider generation costs and ignore social, environmental and transmission costs. PDPs specify what types of power plants will be built in each year. Once past this planning stage, it is difficult to make changes. Cost planning should be based on the full economic costs of delivered electricity services to end users.

An alternative to PDPs is IRP, which:

- considers society-wide perspectives
- incorporates public participation in meaningful ways
- has a strong track record in low-cost, low-risk, low environmental/societal impact planning
- includes a strong energy efficiency/demand-side management approach.

Energy efficiency is included because often helping customers save electricity is less expensive than building and operating new power plants. The IRP process emphasises that both supply and demand-side options must be considered equally. But IRPs challenge the conventional electrical utility “culture,” as energy efficiency (EE) measures threaten to lower utility revenues that utilities earn from selling electricity.

**What are conventional power sector planning practices?**

Generally speaking, conventional planning takes the form of a bundle of practices referred to as “least-cost planning” – that is, least cost from the utility’s financial perspective. The utility typically develops a plan through load forecasting, a limited list of options and algorithmic optimisation.

**Load forecasting** is necessary because supply must be balanced with demand at every moment, since electricity cannot be cost-effectively stored on a national scale. Peak demand and a mandated reserve margin determine the amount of installed generation capacity needed to ensure an adequate power supply. As power plant development can take years, there is a need to plan years ahead in order to avoid future shortages. Inaccurate forecasts can lead to shortages or surpluses, both of which have a great impact on the economy. The methodology for long-term GDP demand projections is based on economic growth predictions and some electricity elasticity factors.

This methodology relies heavily on econometric forecasts. As economic forecasts may fail to capture the progress of technological developments in EE and changes in energy services, they have in many cases produced demand projections that exceeded real growth in the demand for electricity. For example, over-predicting demand in the Pacific Northwest of the United States cost consumers USD 7 billion in over-investment. In 1983, this led to the second-largest municipal bond default in US history.

The **generation requirement** is generally determined in terms of peak capacity and maintaining a minimum reserve margin beyond projected peak demand. But the assumed reserve margin can heavily influence the number of power plants required.

Poorly negotiated PPAs have mainly been the result of non-competitive and opaque bidding procedures prone to corruption, insider deals and nepotism (ADB, 2003). In Indonesia, for example, the overwhelming majority of PPAs were contracted based on non-competitive and often unsolicited bidding procedures. Furthermore, PPAs often included take-or-pay conditions and frequently closed on convertible currencies or were fully indexed to exchange rate variations (ADB, 2003). During the Asian financial crisis local currencies depreciated substantially and the cost of PPA contracts soared in domestic currency terms. However, the impact of currency depreciation could be dampened by IPP financing based on local debts. Local debt financing was 90% in Malaysia and 75% in Thailand; in contrast, it was only 14% in Indonesia and 3% in the Philippines (World Bank, 2015).

Take-or-pay clauses led to the paradoxical situation that utilities frequently had to reduce their own generation and absorb the higher priced output from IPPs if demand was overestimated or decreased rapidly due to economic shocks. In order to recover costs, utilities either had to adjust tariffs or renegotiate PPAs. While the first option led to hard opposition among consumers (e.g. Indonesia),

the latter has been at the expense of potential investor confidence. Planned IPP projects which were still under negotiation were either cancelled or indefinitely postponed. As a result, after the financial crisis in 1997, private investment in the power sector remained low for several years (see Figure 2.4).

While the first IPP experience was mixed and certainly not the most cost-effective, the costs of unserved electricity due to under-investment in power generation are much higher. A study carried out by the Energy Policy and Planning Office (EPPO) of Thailand, for example, revealed that the cost of unserved energy amounted to more than Thai baht (THB) 50 000 /megawatts per hour (MWh) (USD 1 250 MWh) (EPPO, 2001).<sup>11</sup>

Electricity reform continued both during and after the Asian financial crisis. In fact, in countries receiving structural adjustment loans (SALs) from the World Bank (such as Thailand, Philippines and Indonesia), electricity reforms were usually part of the negotiated loan conditions. However, reform attempts were soon suspended or abandoned for a variety of reasons. For example, in the wake of the California power crisis, Malaysia, as many other countries worldwide, decided to suspend further reforms and adhere to the single-buyer model. Indonesia, on the other hand, in 2002 passed a comprehensive electricity reform act, which outlined a pathway to liberalisation including unbundling, privatisation, wholesale competition, market-driven tariffing and independent regulation. However, in 2004 the Constitutional Court of Indonesia annulled this electricity law, arguing that it did not comply with the Indonesian constitution. The Constitutional Court in particular construed the privatisation of PLN, the Indonesian state-owned utility, as being unconstitutional and the previous law from 1985 was re-installed. In 2009, the Indonesian government passed a new electricity law, which is in compliance with the constitution and which gives private investors an opportunity to actively participate in the electricity sector. State-owned companies, regionally-owned companies, private business entities, co-operatives, and community initiatives may supply electricity for public use, but the right of first priority is still vested in PLN. Further sector reform efforts would apparently require changes in the Indonesian constitution (Vagliasindi and Besant-Jones, 2013).

In Thailand, the Thaksin administration abandoned reform plans that called for an electricity sector organisation similar to the power pool model adopted in the United Kingdom (Jarvis, 2010). Instead of the pool model, the Thaksin administration installed an enhanced single-buyer model. Singapore and the Philippines were the only countries that proceeded to restructure their sectors to become fully liberalised markets. The single-buyer model in different variants has thus become the mainstay of ASEAN power sectors and so will probably continue for the time being (see Table 2.1).

**Table 2.1 • State of electricity regulation in ASEAN member countries**

Country	Regulator	Regulator independence	Market structure
Brunei Darussalam	Dept. of Electrical Service	Under the Ministry of Energy	Single buyer
Cambodia	Electricity Authority of Cambodia	Independent	Single buyer
Indonesia	Dept. of Energy and Mineral Resources	Under the Ministry of Energy and Mineral Resources	Single buyer
Lao PDR	Dept. of Electricity	Under the Ministry of Energy and Mines	Single buyer
Malaysia	Energy Commission	Independent	Single buyer
Myanmar	Ministries of Electric Power	Under the Ministries of Electrical Power	Single buyer
Philippines	Energy Regulatory Commission	Independent	Price pool
Singapore	Energy Market Authority	Under the Ministry of Trade and Industry	Price pool
Thailand	Energy Regulatory Commission	Independent	Single buyer
Viet Nam	Electricity Regulatory Authority	Under the Ministry of Industry	Cost-based pool

Source: Syaiful, I. (2015), "ASEAN power market integration", presented at ACE-HAPUA-IEA-World Bank Workshop, 13 March 2015.

<sup>11</sup> USD 1 was approximately THB 40 at the time of the EPPO study (2001).

Limited modelling software and limited data make modelling a few large power plants much easier than hundreds of smaller plants or alternative measures. Some planners just do not consider EE or the demand side as options, and they may assume a “snapshot” fuel price. Assumed discount rates can also have different implications. A high discount rate (under which future cash flows have a relatively lower value) favours fossil-fuelled generation because it has relatively low capital costs but high/uncertain fuel, operating and maintenance costs. Low discount rates favour investments in renewables and EE because they have low ongoing costs but generally high upfront capital costs.

### Box 2.2 • Case study: Philippines – From private sector investment to electricity wholesale markets

The development of the Philippine electricity sector began with substantial private investment. Independent power producers entered the Philippine market in 1988 as a response to costly and chronic blackouts. The government’s inability to finance the power sector made private investment necessary. After the power crisis subsided, the Philippines continued to contract IPPs in order to support the high expected economic and demand growth. This became the foundation for the push towards a competitive wholesale energy market.

Despite the Asian financial crisis in the late 1990s which rendered PPAs unsustainable, the government continued to honour IPP contracts for several years. Throughout the turmoil, the Philippines tried to move towards an unbundled, privatised system in which electricity is sold in a wholesale market at fluctuating spot market prices. Finally, in 2001 the Wholesale Electricity Spot Market (WESM) was established, and since then the government has shown strong commitment to the liberalisation of electricity markets.

The IPP experience in the Philippines illustrates several common themes in the global IPP experience. In the Philippines, successful plans to increase private participation were critical for the introduction of competitive electricity markets. IPPs in the Philippines stuck through an ever-changing legal environment for foreign capital and several distinct energy regulatory regimes. The political and social arena for private energy investment has proven volatile but manageable. In the Philippines, as in many developing countries, there is significant popular dissatisfaction with electricity reform efforts, which is a red flag for foreign investors. The IPP sector itself has been particularly sensitive. Despite investors’ hesitation regarding the rule of law and governance issues in the Philippines, investors have proven responsive to legal incentives, favourable contract terms, and sophisticated contractual safeguards and have invested in the power sector.

Liberalisation is not a panacea for power sector governance. Good power sector governance and efficiency may also be achieved under different arrangements. Regardless of the power sector market design chosen, power sector development needs a strong, reliable, and depoliticised governance framework. Reform steps such as establishing a solid and reliable legal basis through advanced electricity legislation, corporatisation, commercialisation, account unbundling, and powerful regulatory bodies may all be established under single-buyer arrangements. A precondition for such a governance framework is an independent and strong regulator. To ensure the independence of the regulatory authority it must be depoliticised, formally separated from the executive branch (i.e. ministries, etc.), and governed by statute without any de facto executive political influence on the regulation process. Consequently, the regulator should operate within the powers delegated to it by the legislature and thereby remain subject to long-term electricity sector policy.

The United States for example, has experience and a long tradition of electricity sector governance and regulation in vertically integrated/single-buyer arrangements (RAP, 2013). There are powerful regulatory measures such as incentive regulation or IRP which provide the required tools to effectively increase power sector efficiency and transparency, and ASEAN countries should view improving their power sector governance frameworks within the context of meeting their development goals.

## Implications of renewable energy integration for ASEAN markets

### Page | 38 Renewable energy in ASEAN

Since 1990, the generation of electricity in ASEAN countries has expanded dramatically with a compound annual growth rate (CAGR) of 8%, which implies a doubling roughly every ten years. Electricity generation grew from 154 terawatt hours (TWh) in 1990 to above 756 TWh 2012. This enormous growth has been predominantly realised by capacity expansion of coal and gas-fired power plants, which provided more than three-quarters of the electricity produced in 2012, up from a 30% share in 1990. Renewable electricity generation held a significant share of about 17% in the 2012 ASEAN power mix; 14% was produced by hydro resources and 3% by geothermal resources. Use of other resources such as bioenergy, wind and solar is only contributing marginally.

In the current market, technological and political conditions, the dominance of fossil fuels in the ASEAN power generation mix is expected to prevail in future scenarios unless policies change significantly (see Table 3.1) (IEA, 2013a; ADB, 2013).

**Table 3.1 • ASEAN electricity generation by source (TWh)**

Source	Share				2013-40	Share	
	1990	2013	2020	2040		2013	2040
Fossil fuels	120	648	925	1 731	3.6%	82%	77%
Coal	28	255	482	1 097	5.6%	32%	50%
Gas	26	349	406	578	1.9%	44%	26%
Oil	66	45	45	24	-2.2%	6%	1%
Nuclear	0	0	0	32	n/a	0%	1%
Renewables	34	141	180	481	4.7%	18%	22%
Hydro	27	110	119	255	3.2%	14%	12%
Geothermal	7	19	27	58	4.2%	2%	3%
Bioenergy	1	10	22	75	7.7%	1%	3%
Other	0	1	12	93	16%	0%	4%
<b>Total</b>	<b>154</b>	<b>789</b>	<b>1 104</b>	<b>2 212</b>	<b>3.9%</b>	<b>100%</b>	<b>100%</b>

Hydropower is by far the most firmly established renewable energy (RE) source with a significant amount of unused potential. Lao People's Democratic Republic ("Lao PDR") alone, for example, has an estimated hydropower potential of 23 000 megawatts (MW); its current installed capacity (2012) is only 3 205 MW. Historical hydroelectric generation, supply, export and import in Lao PDR, as presented in Table 3.2, show that most of the generated electricity is exported to neighbouring countries.

At present, geothermal energy contributes about 3% to ASEAN's generation mix. The Philippines is one of the largest producers of geothermal energy in the world, second only to the United States in terms of installed capacity. In 2012, geothermal generation amounted to 10.25 TWh of electricity produced. Based on its National Energy Policy, Indonesia also plans to realise its estimated 29 gigawatts (GW) of geothermal potential, building from an existing installed capacity of 1 341 MW (as of May 2013).

**Table 3.2 • Hydroelectric generation, supply, export and import in Lao PDR**

Year	Generation (GWh)	Domestic supply (GWh)	Export (GWh)	Import (GWh)
2001	3 653.7	710.3	2 871.4	183.8
2008	3 717.0	1 915.7	2 315.4	844.5
2011	8 449.0	2 440.7	6 646.5	1 209.7
2012	12 979.5	2 555.7	10 668.4	904.3

Note: GWh = gigawatt hours.

Source: Vongsay, A. (2013), "Energy Sector Development in Lao PDR", presented at Energy Policy Training Course, Tokyo, Japan.

ASEAN countries also have diverse biomass feed stocks ranging from agriculture and forestry residues to forestry products. As an agricultural country, Thailand is rich in agricultural wastes and products that can be processed for energy purposes such as biomass, biogas, biodiesel, ethanol, and by-products from the processed food industry. In 2012, the installed capacity of biomass and biogas was 2 153.4 MW (including off-grid). Indonesia also has high biomass potential amounting to 13 662 megawatts electrical (MW<sub>e</sub>). However, as of 2012, the amount of its on-grid installed biomass capacity was only 75.5 MW<sub>e</sub>.

### Box 3.1 • Hydropower development in Southeast Asia

Southeast Asia has significant untapped hydropower potential – on the Mekong River alone, only 10% of its estimated hydropower potential has been developed. In a region where millions lack electricity, hydropower is seen as a way to increase access to electricity without importing fuels or increasing carbon dioxide (CO<sub>2</sub>) emissions. Some countries see hydropower as their key to economic growth - Lao PDR, for instance, aims to become the "battery of Southeast Asia" by increasing hydroelectricity exports to neighbouring countries. Its total hydropower potential is estimated at 23 000 MW, but only 3 205 MW had been developed by 2012. In the Greater Mekong Subregion, 11 hydropower plants were operating in 2011, and another seven were under construction, mostly in Lao PDR.

Despite this potential, hydroelectric dam construction can cause serious social and environmental disruptions in Southeast Asia. In parts of the region, dam construction has already displaced communities, flooded farmland and reduced water quality. An estimated one-third of the 60 million people living in the Lower Mekong River Basin have a primary occupation linked to the river - in fishing, farming and other sectors. Hydropower development is likely to disrupt the ecosystems that this population relies on for food and income, such as fisheries and the seasonal flood cycles that fertilise agricultural land.

Hydropower generation itself may be disrupted by changes in Southeast Asia's precipitation patterns that are linked to climate change. While precipitation in the region is predicted to increase overall, Southeast Asia is also expected to face more extreme periods of drought and flooding. Drought (and even annual dry seasons) could reduce hydropower generation, as occurred on Thailand's Mun River. Dam construction can also make seasonal floods more extreme and dangerous, as reports on devastating floods in India have shown.

Given the pressures that population growth, electricity demand, and climate change are expected to put on shared water resources such as the Mekong River Delta, Southeast Asian countries will need to co-ordinate their hydropower development and share information on water usage to avoid interfering with the other useful resources that waterways provide. Also, with more interconnected power grids, ASEAN nations could take advantage of complementarities between different river systems to develop hydropower in ways that are more efficient and sustainable.

Techno-economic characteristics among renewables generation technologies indicate that hydropower will remain dominant in the future (see Table 3.1; cf. IEA, 2013a and ADB, 2013). Small-scale solar PV generation at the distribution level could become financially attractive, both



for consumers in remote locations and in grid-connected locations with high retail tariffs. Here, captive generation and the self-consumption of solar PV generated electricity may become a cheaper option than electricity bought from the grid; this is when renewables reach so-called grid parity. However, to support the development of a wider mix of renewable technologies, many ASEAN countries have developed policies with individual RE targets, primarily to diversify electricity generation and increase domestic security of supply. Besides using renewables on the domestic front, ASEAN countries also see RE as an opportunity to create local champions to manufacture the products required in a future carbon-constrained world. Already today many PV module manufacturers are located in Southeast Asia (e.g. in Malaysia, Philippines, and Thailand). In 2013, one-third of PV module imports into the United States came from Malaysia and the Philippines (Platzer, 2015). To date, the costs of generating electricity from non-hydro RE technologies are still higher compared to conventional power generation. This economic disadvantage can often result in slower development of non-hydro RE technologies, despite their various benefits. As a significant portion of the ASEAN population is within the lower-income consumer category, the lowest electricity supply costs are often favoured by decision makers to reduce the financial burden on consumers.

Local lending conditions set by the private sector will play a crucial role in the future to drive down the costs of non-hydro RE technologies. In various cases these lending conditions have a greater cost implication compared to local conditions in terms of wind speed or insulation (Ondraczek, Komendantova, and Patt, 2015). IEA experience suggests that, due to their technical characteristics, a higher share of new renewable technologies such as wind or solar PV can come with additional costs for system integration (IEA, 2014a). The integration costs will vary by jurisdiction and depend on various technical and regulatory factors that must be assessed. However, a low share of 2% to 3% of variable renewables is often observed to have marginal added integration costs only. IEA experience suggests that reaching a higher, but still comparably low, share of 5% to 10% of variable renewables is technically feasible if certain basic technical principles are adhered to from the early beginning: managing supply-side variability of a share of more than 10% is significantly below the share already being managed (e.g. 21% of annual generation in the Iberian Peninsula and instant penetration of more than 75% in countries like Denmark and Germany), but this often raises concerns with utilities managers and system operators in ASEAN. Apart from current economics, the perception of negative reliability is likely to be one of the greatest barriers for the deployment of variable renewable resources.

The current characteristics of renewables, in terms of costs and technical features, will probably not lead to significant investment in non-hydro renewables in ASEAN countries without additional financial incentives and support schemes. One exception may be solar PV, which may, under certain circumstances, diffuse into the power system due to the economics of behind the meter generation.

Encouraging investment to take renewable generation from small- to large-scale will continue to require policy makers to evaluate the needs of the population for targeted interventions and to take active steps to support their integration. Various support schemes exist and have proven their effectiveness, although cost efficiency is another important factor to be considered by policy makers. Apart from the implementation of support schemes, IEA evidence suggests that the targeted development of renewable resources benefits from a systemic perspective, which takes into account the overall power system and the implications of renewable resource development for users. Determining enforceable implementation targets for renewable technologies can further help to identify their systemic impact on the technical and economic level (e.g. price implications for consumers). Targets can also be a decisive tool in overcoming potential institutional inertia and to inform about the continuous evaluation of progress.

## Support schemes for RE

Support schemes can generally be divided into price-based or quantity-based instruments (see Table 3.3 and Table 3.4). That is, prices for renewable electricity feed-in are either set or utilities are obliged to fulfil quantitative RE targets. Price instruments such as feed-in-tariffs (FiT) provide certainty about the price for RE, but uncertainty about the overall achievement of the target. If prices are too low, the target may not be reached. On the one hand, if prices are too high this may result in over-fulfilment of the target, achieving high profit margins for investors and associated unnecessary financial burden for governments and/or consumers. Quantitative instruments such as quotas, on the other hand, can potentially provide greater certainty about quantitative target fulfilment but associated prices are uncertain. Besides this strict dichotomy of price versus quantity, there are also mixed forms which try to take advantage of both approaches.

**Table 3.3 • Price-based instruments and their characteristics**

Type of price-based instruments	Characteristics
i. FiT	<ul style="list-style-type: none"> <li>▪ Regulated tariffs granted by the government to the producers of RE in the form of total price per energy provided for a certain period of time. The motivation is to ensure a profitable operation and pay-back of capital costs to the producers. Usually, this is combined with priority grid access and a guaranteed purchase of electricity.</li> <li>▪ If tariffs are high enough to provide investment incentives, FiTs are highly effective in stimulating expansion of RE. In practice, many FiTs are regularly amended (decreased or increased) by government-established limits to counteract any expected over- or under-fulfilment.</li> <li>▪ Can be a fixed price, but also refer to the variable market price of electricity or the price of avoidance of conventional generation. The FiT may additionally mean a contract for difference (CfD), which makes up the price difference between a market price and a fixed price.</li> </ul>
ii. Fiscal subsidies or funds	<ul style="list-style-type: none"> <li>▪ Fiscal incentives usually take the form of tax exemptions or tax reductions, e.g. value added tax or import taxes. In countries where these taxes are very high the exemption can be sufficient to stimulate renewable generation.</li> <li>▪ In most cases the instrument is applied as a complement to other support schemes.</li> </ul>
Quota obligations and tradable green certificates (TGC)	<ul style="list-style-type: none"> <li>▪ Quota systems are also called renewable energy portfolio standards (RPS).</li> <li>▪ Policies with quota systems place obligations on the market participants (generators, suppliers, consumers) to fulfil a certain percentage of their produced, purchased, or consumed energy with RE. The quota for one period is unalterable and must be fulfilled by every obligated party.</li> <li>▪ The target achievement is given in the quota obligation system according to the definition, otherwise penalties must be paid. In cases where obligations and output are tradable between suppliers and consumers, this penalty then simultaneously constitutes the upper limit for the TGC price.</li> <li>▪ The TGC price, plus any possible revenue from electricity sales, needs to be sufficient to cover total generation costs and should reflect the associated costs for the required marginal supplier.</li> <li>▪ Usually, the system includes trading of TGCs between producers and suppliers or consumers of electricity, independently of the physical electricity market.</li> <li>▪ Most quota systems have a technology neutral support, leading to the deployment of the cheapest and usually most mature technology at the best site. However, there are variations which allow technology-specific support such as the banded quota system. Here, the number of certificates issued to an operator of a renewables plant depends on the electricity generation technology.</li> </ul>
Technology-specific tender	<ul style="list-style-type: none"> <li>▪ Tenders or auctions specify a quantity of RE capacity or average energy generation for every period to be contracted in a bidding process. The cheapest bids will be rewarded and set as individual prices over the contracted years.</li> <li>▪ Often, tenders are held for specific technologies because of different generation profiles and costs. The quantity is stipulated by the political goals. Public institutions will carry out and monitor the auctions and implementation of projects.</li> <li>▪ Price-setting depends on competition in the market. Low quantities may impede market development and result in high prices or a lack of offers.</li> <li>▪ Tenders do not need competitive supply or a retail market on the demand side.</li> </ul>

Feed-in-tariffs are the dominant support mechanism worldwide (see Figure 3.1). Most ASEAN countries which use support schemes to promote renewables have also implemented some type of FiT (see Table 3.4).

**Table 3.4 • Support schemes in ASEAN countries**

Type of support scheme	ASEAN country	
FIT	Production cost-based	Malaysia (since 2010)
		Philippines (since 2008)
		Thailand (since 2006)
Avoided cost tariffs		Indonesia (2012 geothermal tariff)
		Viet Nam
Premiums over market price	Thailand	
Tender	Direct auctions	Indonesia (tenders for geothermal work areas)
	Auctions for subsidy	Thailand (funded from the tax on petroleum products)
Quota	Philippines (since 2008)	
Subsidies	Direct capital subsidies	Philippines (grants to consumers for PV systems)
	Preferential domestic financing	Thailand
	Preferential foreign financing	Indonesia (Carbon Trust Fund support to geothermal projects)

Source: Meier et al. (2015), *The Design and Sustainability of Renewable Energy Incentives – An Economic Analysis*, World Bank, Washington, D.C.

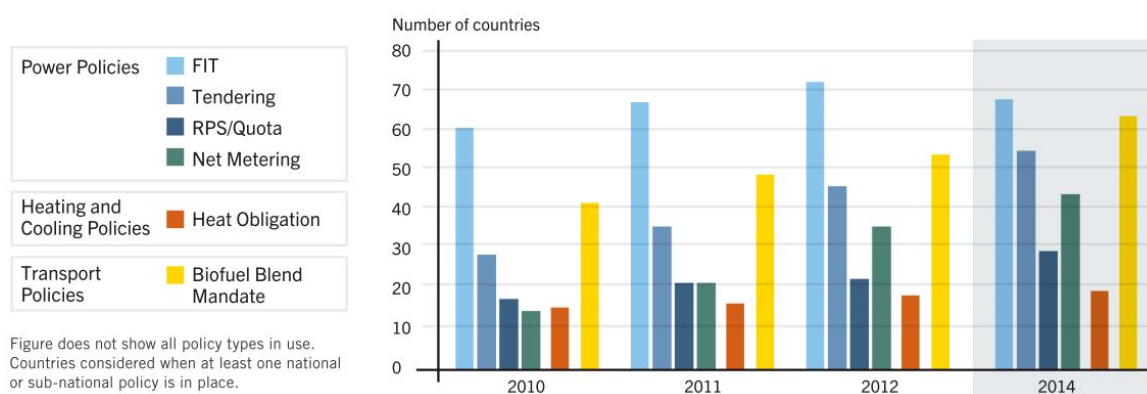
**Figure 3.1 • Countries with renewable generation support schemes**

Note: Figure does not show all policy types in use. Countries considered when at least one national or subnational policy is in place.

Source: REN21 (2015), *Renewables Global Status Report 2014*, [www.ren21.net/gsr](http://www.ren21.net/gsr).

One reason for the worldwide popularity of the FIT is that it can be implemented in practically any power market regardless of the electricity market design, its economic structure, or supported RE technology. Furthermore, it has been proven to be very effective in quantitative target fulfilment. However, due to worries about the cost effectiveness and market conformity of FIT, a significant number of countries have made a policy shift from FITs to other instruments such as competitive tenders or auctions (e.g. Brazil and South Africa) or use FITs in addition to other instruments. Some countries, however, have shifted from quota systems to FIT regimes

(e.g. the United Kingdom). Overall, tenders, quotas, and net metering are about to catch-up. With all support schemes it is important for power system governance decision makers to:

- take into account rapidly falling renewable generation costs
- address tax/rate-payer burdens
- account for RE's cost competitiveness
- ensure reliable and affordable system integration of variable renewable power.

## Integration of renewable resources into national power systems

The integration of significant shares of renewable resources is an important factor for increasing electricity demand, diversifying the electricity generation mix and decreasing import dependencies on conventional fuels. Renewable energy sources are abundant in Southeast Asia and remain an important and, in some countries and subregions, dominant source of energy supply. Considerable potential remains untapped in the form of hydro facilities (particularly in the Greater Mekong Subregion, but also in Indonesia and Malaysia), although these are often far from demand centres, and environmental and social challenges are making them more difficult to develop. The technical potential is also great for bioenergy (from feedstocks such as agricultural and forestry crops and residues, animal residues and municipal solid waste). Furthermore, Indonesia has 4 400 MW of planned geothermal capacity additions in the pipeline. ASEAN's prospects for dispatchable renewable generation are thus promising.

Renewable energy can broadly be divided into two different technology classes: dispatchable and variable generation technologies. Dispatchable generation units can usually be fully dispatched within their capacity limits. As such, these capacities are continuously available, unless they are undergoing maintenance. Hydro power with reservoir, however, may have additional restrictions due to seasonal wet and dry cycles.

**Table 3.5 • Technology classes for RE**

Dispatchable generation	Variable generation
<ul style="list-style-type: none"> <li>▪ Hydro with reservoir</li> </ul>	<ul style="list-style-type: none"> <li>▪ PV power</li> </ul>
<ul style="list-style-type: none"> <li>▪ Geothermal power</li> </ul>	<ul style="list-style-type: none"> <li>▪ Wind power</li> </ul>
<ul style="list-style-type: none"> <li>▪ Biomass</li> </ul>	<ul style="list-style-type: none"> <li>▪ Hydro run-of-river</li> </ul>

The generation characteristics of new renewables such as wind and solar PV provide challenges for power system operation. However, their use is growing. Thailand, in particular, is rapidly installing solar PV capacity, encouraged by supportive government policies. Generally, PV and wind and other technologies such as concentrated solar power (CSP) have reasonable potential in the region if supported by adequate policies.

In contrast to dispatchable generation technologies, variable resources cannot adjust their power output to demand as they are dependent on instantaneous wind speeds, insulation and cloud coverage. As a result, these technologies often have low capacity credits and need (flexible) back-up capacities that balance their variable output. For wind, the capacity credit is a measure of firm capacity as a fraction of total installed capacity.

Assessments of capacity credits are generally complex, data intensive and have different methodological approaches that tend to deliver (slightly) different outcomes. However, in Europe, generally, the capacity credits for solar PV are 2% or less, and credits for wind are in the range

between 5% and 35%.<sup>1</sup> Globally the ranges are far wider for solar, rising to 65% in the most favourable cases. Low capacity credits, the variability of power generation, and the fact that renewables have virtually no operational costs can have significant influence on both short and long-term power sector operation, composition and economics. Low capacity credits also imply that even with a high proportion of variable renewable energy sources (vRES) the requirements of conventional (dispatchable) generation technologies are not reduced in proportion to their shares of generation. These dispatchable technologies, however, must be flexible enough to cope with variability and associated ramping requirements. A power system with a larger proportion of variable renewable technologies will often require fewer base load plants, but more flexible generation, demand-side response, storage and interconnections.

With least-cost dispatch according to merit order principles, which is, in theory, the way dispatch takes place, both in liberalised and in single-buyer markets,<sup>2</sup> vRES are dispatched first as they virtually have no operational costs.<sup>3</sup> Conventional generation needs to cover the residual load, which is the demand reduced by the renewable generation. If renewable generation decreases the need for conventional power generation, the more expensive units will not be dispatched.

In liberalised (spot) markets this is ultimately translated into lower electricity prices and this effect has been named the “merit order effect of renewables” (Sensfuß, 2008). The merit order effect is also likely to be relevant in ASEAN countries. For example, a study conducted by the National Renewable Energy Board (NREB) of the Philippines estimated that the entry of 200 MW of FIT-supported vRES, would have reduced prices in the wholesale electricity spot market (WESM) in Luzon by between Philippine peso (PHP) 0.59 and PHP 3.15/kWh, or an average reduction of PHP 0.17/kWh nationwide (GIZ, 2013; McConnell, 2012).

While the merit order effect is mainly a short-term impact, in the long run, high proportions of vRES change the economics of conventional technologies. With decreasing load factors due to a high share of vRES, the specific generation costs of conventional technologies increase (see Figure 2.4). This favours less capital-intensive technologies (such as gas) at the expense of capital-intensive technologies (coal and nuclear), though this strongly depends on the relative fuel prices.

Even if the specific electricity generation costs of variable renewable generation become competitive with dispatchable thermal generators, there will still be fundamental differences between variable (non-dispatchable) and controllable (dispatchable) units. In this respect commonly applied approaches to cost determination (e.g. levelised cost of energy methodology) can be misleading, as they do not capture the integration costs associated with variability and only limited abilities to dispatch. Complementary resources (dispatchable generation units, storage units or demand reduction) must then provide back-up for vRES generation.

The integration of renewable energy requires grid operators to rethink how they develop and use their network infrastructure. Renewable energy projects are often located in remote areas, produce with lower foreseeability and vary their output within seconds and require more dynamic operations to maintain stability of the overall power system. Renewable generation needs to be metered so that consumers can be rewarded with support schemes; real-time grid monitoring and a management infrastructure are also necessary to avoid imbalances and to manage congestion. Certain aspects of the generation of renewables, such as production

---

<sup>1</sup> The capacity credits of wind depend on a number of factors, including the local wind resource, load profiles, geographic spread, turbine technology, and penetration levels.

<sup>2</sup> Inflexible or non-dispatchable power purchase contracts in single buyer models may lead to deviations from least-cost dispatch principles. However, by and large, dispatch follows merit order and least-cost principles.

<sup>3</sup> In this respect, the priority dispatch of vRES, often as part of FIT regulations, is redundant since economics will force vRES to be dispatched first anyway.

variability and unpredictability, the zero marginal cost of generation, and their strong site specificity, often make them a technical and economic challenge.

The use of renewable generation can benefit from a regional power market, especially where different renewable technologies can be combined with dispatchable hydropower stations.

## Developing regional electricity markets

When considering how best to develop national power sectors, policy makers are constrained by the energy policy trilemma: ensuring that power systems are reliable, affordable and clean. Maximising any one goal often requires compromise on the others. For example, minimising investments in order to lower costs may compromise system reliability, and may also require investment in cheaper generation with higher environmental impacts, such as low-efficiency coal.

All policy makers face the energy policy trilemma, but these difficulties are particularly pronounced in regions such as ASEAN, where power sector goals must compete with other development goals, such as continued industrialisation, and where national geographies place limits on available natural resources.

It is for precisely this reason that power market integration in the ASEAN community is so important. Regional collaboration, while presenting its own challenges, can minimise the tension between these three policy goals. An integrated system is more reliable because it gives all parties access to more – and more diverse – resources. However, the reliability of an integrated market can be undermined without the implementation of appropriate and harmonised regulatory frameworks.

Integrated power systems are also more affordable, as they can make the most efficient use of all available assets. To be truly cost-effective, however, some countries may have to reduce their reliance on domestic resources in favour of increased interconnections with neighbours – a challenge even in more integrated markets such as those in Europe.

Finally, power sector integration also allows renewable resources to be developed in the most efficient locations. This, though, may require additional spending on transmission capacity and may also require development in environmentally sensitive areas.

The following sections discuss in more depth the benefits of integration, and the policies and regulations that best support regional integration.

### Benefits of integration

Historically, power sectors have tended towards increasing the size and level of their integration. Larger systems are better able to reduce costs through economies of scale, take advantage of resource diversity, and integrate variable renewable generation. At the same time, large systems are more complex, and therefore more difficult to manage. The complexity is further increased when large power systems stretch across national borders, and in particular when those countries are as diverse as the members of ASEAN. As the following sections will make clear, however, the benefits of integration are real and significant, and it is possible to integrate without sacrificing national priorities.

In considering the benefits and challenges of power system integration, it is important to keep in mind that these may change depending on the point of view. A system operator who prioritises resource adequacy may wish to have as large a system as possible and would therefore see real benefits to cross-border integration. Policy makers, on the other hand, may prioritise self-sufficiency, and may therefore see a power system that extends outside their own territory as one that potentially undermines their own domestic priorities. Experiences in other countries and regions have shown, however, that the benefits of integration are real and, furthermore, that it is possible to pursue regional integration without sacrificing domestic priorities.

Two primary advantages of system integration are increased security of supply and increased efficiency. Security of supply derives directly from the fact that larger service territories allow for the pooling of generating resources, and indirectly from the fact that neighbouring power systems, to the extent that they are physically interconnected with alternating current (AC) transmission lines, must maintain synchronous frequency – and so are interdependent even if operations are completely separate. Efficiency gains derive from the ability to aggregate demand and take advantage of the benefits of generation diversity.

### ***Security of supply***

Ensuring sufficient supply to keep the lights on is a challenge in all countries, but it is especially difficult in regions that are growing as quickly as ASEAN. On the one hand, rapid economic growth creates an attractive investment environment. On the other hand, growth in emerging economies drives growth in electricity demand, and so investment must be rapid enough to meet both existing and future needs.

Security of supply encompasses three fundamental requirements; i) adequacy, ii) system security and iii) fuel security. System adequacy refers to the ability of supply to meet demand on a consistent basis, including in the event of demand spikes or supply outages. Adequacy is often measured in terms of loss of load expectation (LOLE), or the average number of hours, per year, that supply is insufficient to meet demand. In general, service territories aim to meet as low an LOLE standard as possible while minimising overall cost. Setting a low LOLE target requires building more capacity than is needed for typical use – which means that at least some portion of capacity will be sitting idle most of the time.

Larger service territories are able to meet system adequacy needs in two ways. First, increased overall demand makes it possible to build larger generators than would otherwise be justified, allowing generation developers to take advantage of economies of scale and lower average generating costs. Second, larger geographic areas allow a greater number of generators to be built, so there are more generators available in the event of an outage; these also allow developers to access a greater diversity of natural resources. Therefore, system reliability is improved.

Transmission networks rely on AC technology, and therefore must maintain a stable electrical frequency within specified limits. Most of the ASEAN countries run their network at 50 hertz (Hz).<sup>1</sup> Increased integration within ASEAN will require grid operators to respond to maintain synchronous frequencies while also responding to changes in frequency that may be the result of changes outside their area of control. Changes in frequency can be the result of unexpected generator outages, mismatches between supply and demand, and even improper scheduling of generating resources. Any significant deviation from the standard frequency runs the risk of damaging equipment on or connected to the grid, and perhaps causing outages.

Connected networks must maintain synchronous frequency in order to maintain system operations. In fact, the primary cause of large power outages in the United States and the European Union over the past few decades has been lack of co-ordination between synchronous interconnected power systems. Isolated events can cascade to impact wide territories when system operators, often unaware of the exact cause of a disruption, respond incorrectly. In August 2003, for example, the entire northeastern portion of the United States, as well as a large portion of central Canada, experienced a blackout because of a single plant outage and a line failure. In all, five separate but connected power systems were affected. System co-ordination

---

<sup>1</sup> The one exception is the Philippines, which operates at 60 Hz.



not only makes it easier to manage day-to-day frequency variations, but can prevent local disruptions from bringing down entire power systems.

Given the interdependent connections within Southeast Asia, the security of a regional power supply is an important priority. The co-ordinated development of a regional power system has been a goal of APG since inception.

#### **Box 4.1 • Case study: The 2003 power outage in the northeastern United States and Canada**

In 2003, a heat-induced low transmission line hit a tree and set off a series of electricity line trips. In most cases, inadequate advanced system planning and inadequate operations and reactions to grids in real time contribute to the cross-border blackouts. This blackout, which affected 55 million people across the northeastern United States and provinces in Canada, revealed a lack of adequate cross-border governance of system operation.

In response to this major blackout, the US Federal Energy Regulatory Commission (FERC) has approved new reliability standards and measures to be better positioned to manage cross-border electricity systems and respond to such potential emergency situations. The North American Electric Reliability Corporation (NERC) was chosen to assess the reliability of the grid, develop reliability standards and enforce compliance. New measures include the development of a coast-to-coast real-time monitoring system to view grid information from one place (examination of power systems in isolation does not give a full picture of system interaction). NERC also has the authority to enforce penalties on industry to implement standards. The US federal government and the electricity industry have invested in new technologies to improve data collection, an important component for power system monitoring. Improved system operator training to manage emergency conditions and events, and improved co-ordination, communication and data exchange between system operators at local and regional levels have also been a focus of improved power system management.

### **System efficiency**

All power systems strive for maximum system efficiency. In the growing power systems of ASEAN, however, the benefits of improved system efficiency are even more pronounced, as increased efficiency leads to lower investment requirements and operating costs, freeing up resources for other sectors and making it easier to meet future growth.

Interconnected systems become more efficient on both the demand side and the supply side. In both cases, larger systems are better able to take advantage of system diversity. Peak demand, for example, occurs at different times in different locations, so larger systems are able to better meet demand while avoiding the need to have a high margin of reserves. When peak demand of two connected systems is non-coincident (that is, when it does not occur at exactly the same time), fewer generating resources are required to meet the demand needs of both systems simultaneously than are needed to meet them separately. To see why this is the case, consider Figure 4.1. Here we show very simple demand curves for two hypothetical countries. These curves are identical except for the fact that the peak in Country 2 occurs four hours later than in Country 1.

Each system has a peak demand of 500 MW. It is tempting, therefore, to say that total peak demand in both systems is 1 000 MW. However, because the peaks do not occur at the same time, in absolute terms peak demand is lower – in fact, nearly 100 MW less. This can be seen clearly in Figure 4.2, which shows what total demand would look like if peak demand in Country 2 was coincident with Country 1, and what total demand looks like when peaks are non-coincident, as in Figure 4.1.

**Figure 4.1 • Hypothetical demand curves with non-coincident peaks**

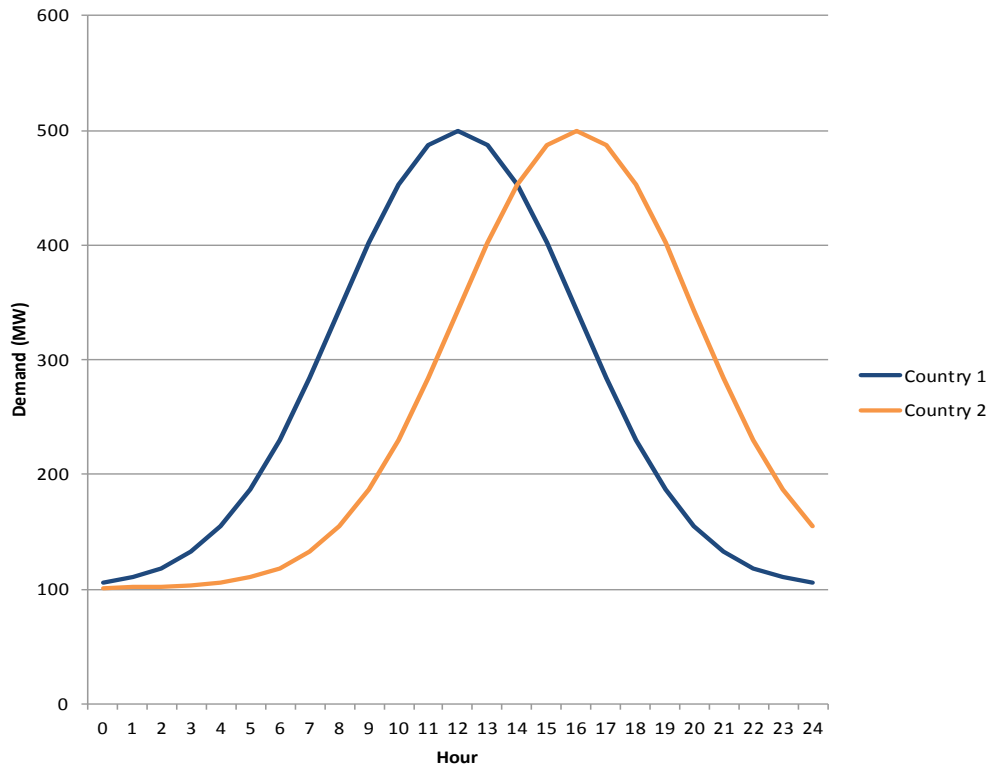

Note: MW = megawatt.

**Figure 4.2 • Total demand, hypothetical coincident and non-coincident peaks**

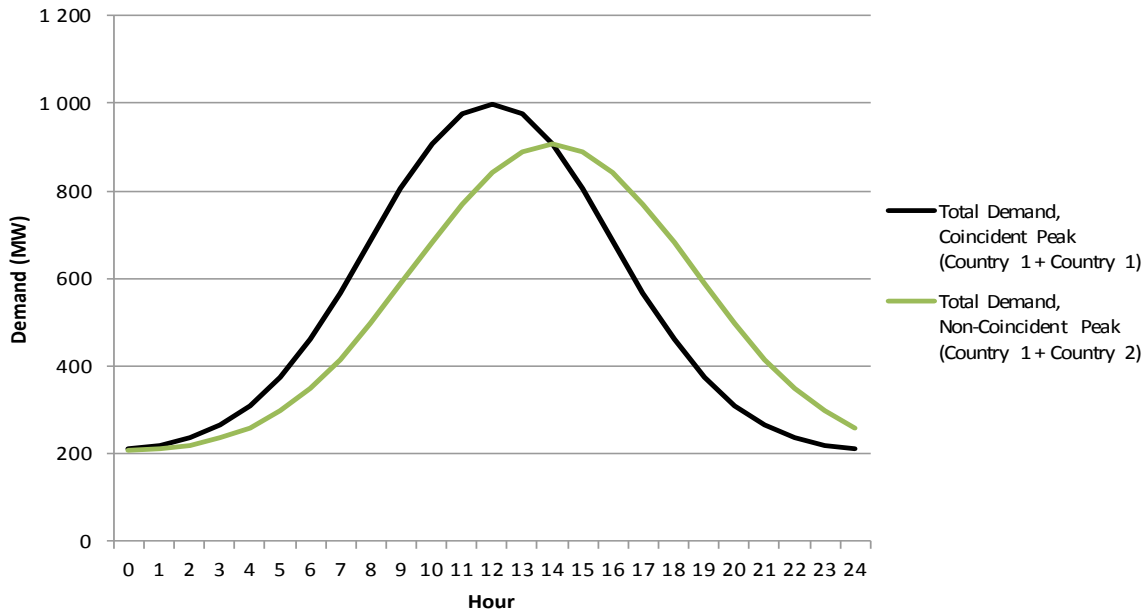

While these examples are hypothetical, real-world experience bears out these results. Figure 4.3 shows peak demand in 16 European countries summed together under the assumption that all peak demands occur simultaneously, and then again taking into account the actual coincidence of demand. In this case, overall system demand is reduced by approximately 25 gigawatts (GW), or 5%.

Figure 4.3 • Peak demand in 16 European countries, 2011

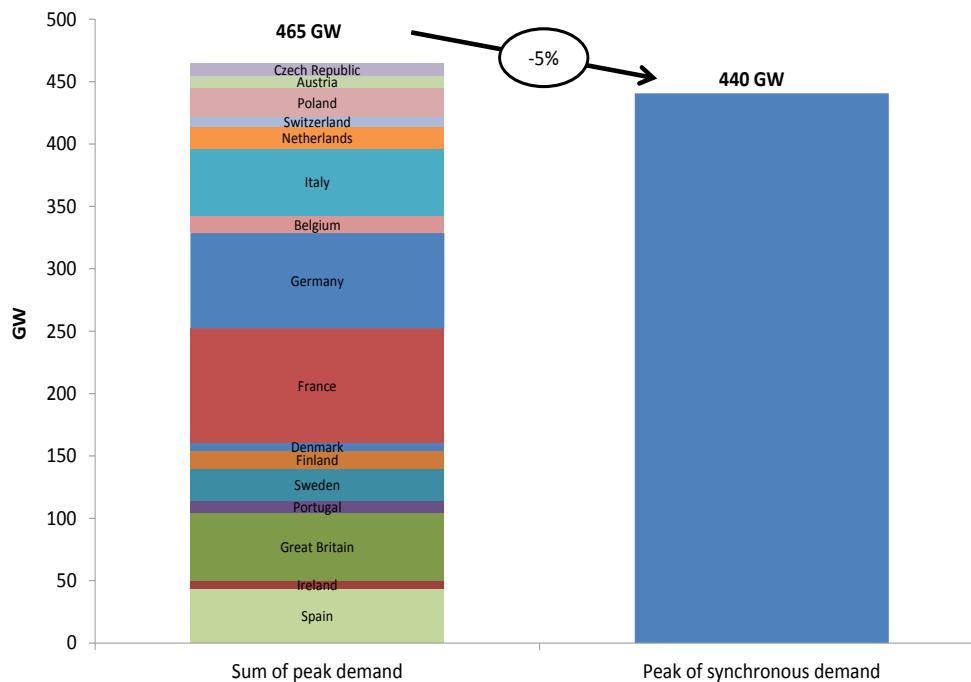

Source: IEA (2014b), *Seamless Power Markets: Regional Integration of Electricity Markets in IEA Member Countries*, Featured Insight, OECD/IEA, Paris.

Increasing the size of a service territory also helps to decrease overall demand volatility. Demand will vary not only over the course of a given day, but also over weeks and months, as weather patterns change and seasons shift. Figure 4.4 shows the average variation in demand over a two-week period in nine European countries, as well as an aggregate demand curve. The aggregate curve shows significantly less variation than that of any individual country.

Figure 4.4 • Variability of demand in nine European countries, first two weeks of January 2011

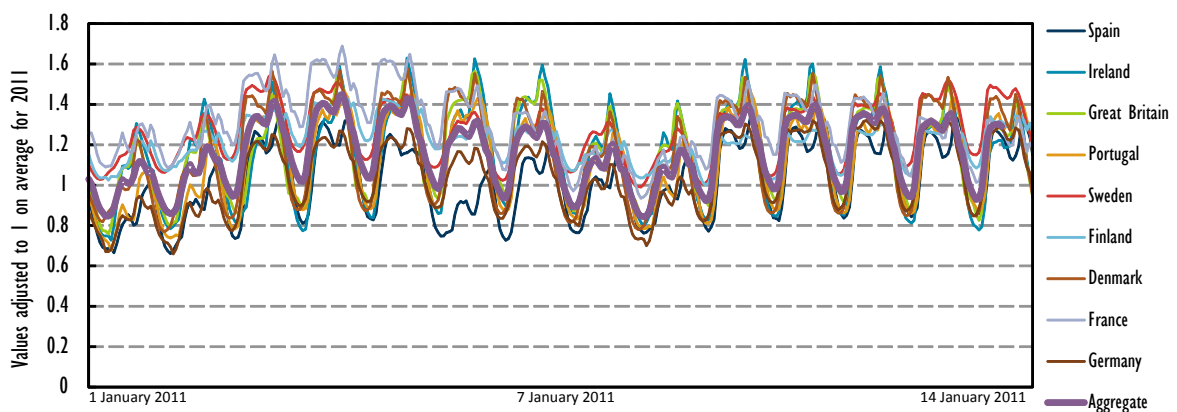

Source: IEA (2014b), *Seamless Power Markets: Regional Integration of Electricity Markets in IEA Member Countries*, Featured Insight, OECD/IEA, Paris.

System efficiency also extends to the supply side. For example, reduction of overall peak demand directly translates to lower requirements for reserve margins. Therefore, investment in generating capacity also becomes more efficient as less capital cost will be required. To achieve this, regional planning should be prioritised over the individual generation planning currently performed by each country. Larger systems are also better able to take advantage of a diverse set of resources. Different

regions tend to develop certain types of generating resources. This may be for geographic regions (for example, the Mekong region's significant hydroelectric potential) or for economic reasons (for example, Indonesia's significant low-cost domestic coal deposits) or even for political reasons, such as maintaining national self-sufficiency. This diverse set of influences nearly always results in a suboptimal generating mix within any given country. Integrating power systems across borders, or at least allowing for the trade of generating capacity between regions, can increase the overall efficiency of a generating fleet by allowing each plant to run more often when it is optimal to do so.

The integration of variable renewable generation into power systems brings a new set of challenges. It is only possible to build renewable generation such as wind and solar where sufficient natural resources are already available, limiting their geographic placement. In addition, the variable nature of wind and solar energy requires other resources in the power system to behave in a more flexible fashion, to fill in the gaps in generation when the wind stops blowing or the sun stops shining, but also potentially to cut back on generation when wind and solar generation produces more generation than is needed but cannot be curtailed.

In the same way that increasing the size of a service area can smooth demand, larger territories can also smooth average resource volatility, allowing for more optimal renewable generation deployment and lowering overall emission levels. Projects such as the ASEAN Power Grid are well suited to provide exactly this sort of benefit. Figure 4.5 shows the variability of wind output in four European countries over a two-week period, as well as the aggregate output. Similar to the aggregate demand curve, aggregate output is significantly less volatile than for any specific country.

**Figure 4.5 • Variability of wind output in four European countries, first two weeks of January 2011**

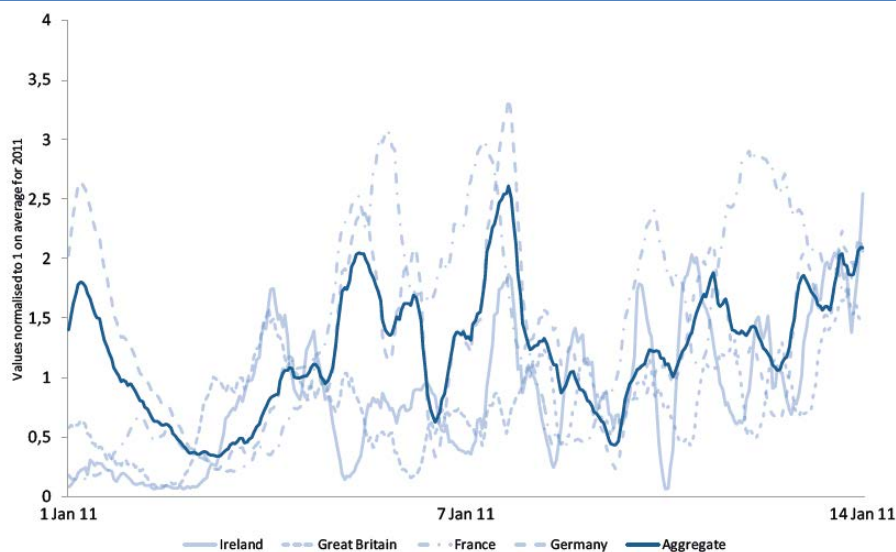

Source: IEA (2014b), *Seamless Power Markets: Regional Integration of Electricity Markets in IEA Member Countries*, Featured Insight, OECD/IEA, Paris.

### **Quantifying the benefits of system integration**

It is one thing to discuss the advantages of power system integration, and another thing altogether to demonstrate that the benefits of integration outweigh the costs. The ASEAN Energy Market Integration (AEMI) study on the benefits of integrating the ASEAN energy market estimates that system costs would decline between 3% and 3.9%, and real GDP would increase by between 1% and 3% (AEMI, 2013). These figures, however, are derived based on full energy market integration, and so include benefits that extend beyond power market integration. It may therefore be illustrative to examine an analysis done for the European market.

First, however, it should be noted that, as the European power system is fully restructured, some of the benefits detailed here are not directly applicable to the ASEAN region. This is because in vertically integrated environments, the advantage that derives from lower wholesale market prices does not exist.

As Figure 4.6 makes clear, however, the majority of the benefit derives not from any price declines but from co-ordinated investment in renewables, declines in generation and transmission costs, and overall system efficiency improvements due to increased integration. For Europe, total net benefits assuming complete market integration are estimated to be EUR 13.6 per megawatt hour (MWh) in 2030.

**Figure 4.6 • Summary of the potential net benefits of European market integration in 2030 (EUR/MWh)**

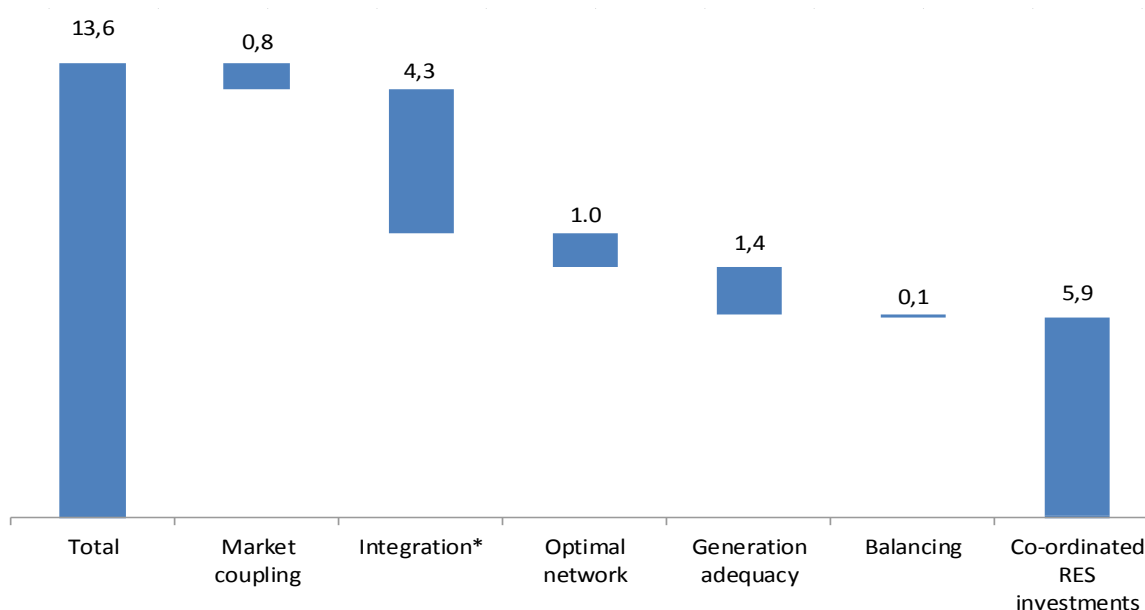

\* With 50% of the optimal additional transmission capacity.

Source: Based on Booz & Company (2013), "Benefits of an Integrated European Energy Market", report prepared for DG Energy<sup>2</sup>

## The role of regulators in establishing regional electricity markets

Regulators play a vital role at the national level, but their role becomes even more important when markets integrate. Within ASEAN, the diversity of responsibilities among national regulators may act as a barrier to integration. Striking a balance between national priorities and the requirements of inter-regional collaboration is challenging, but possible. While it is possible to integrate the power systems of countries that differ significantly, even the relatively lighter touch approach of co-ordination requires a certain standardisation of practices. This is particularly true for regulators, who, in integrated environments, must maintain their national responsibilities while responding to – and being responsive to – developments in other countries. Regulators must maintain a focus on the economic implications of policy decisions, and require independence to maintain a high level of trust and authority among all relevant parties, including the government, the utilities and the public.

Key responsibilities of regulators that must be adapted in interconnected environments are discussed in Figure 4.7 below:

<sup>2</sup> [http://ec.europa.eu/energy/infrastructure/studies/doc/20130902\\_energy\\_integration\\_benefits.pdf](http://ec.europa.eu/energy/infrastructure/studies/doc/20130902_energy_integration_benefits.pdf).

Figure 4.7 • Key responsibilities of regulators

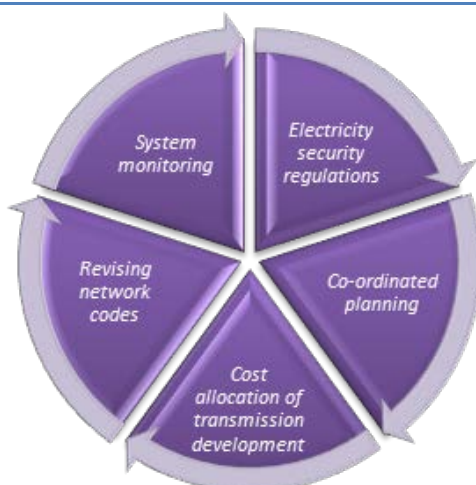

### ***Electricity security regulations***

Regulations that relate directly to electricity security should at a minimum be developed in parallel with, and ideally in advance of, system integration. In practice, electricity security is a complex topic, with many stakeholders and diverging opinions as to how it should be managed. In Europe, member states retain complete control over developing their own reliability frameworks. While the strongly interconnected nature of the European system requires some degree of co-ordination, in practice country-specific preferences often come into conflict with integration efforts.

The United States, which divides regulatory authority over the power sector between the federal and state governments, and which is strongly interconnected with Canada (and, to a lesser extent, with Mexico) has developed a more integrated approach to implementing reliability standards. Reliability standards for the United States, Canada and the northern portion of Baja California, Mexico are developed by the North American Electric Reliability Corporation (NERC). NERC plays an active role in identifying critical infrastructure needs and in capacity building among its members, but its primary role is to develop reliability standards. Standards are developed for a number of different topics, including resource and demand balancing, voltage control, protecting critical infrastructure, developing communication protocols, emergency preparedness, scheduling and co-ordination of interconnections and transmission operations.

While NERC sets standards for the region, because responsibility for actual operations remains at the level of the system operator, actual reliability practices will still vary from state to state, province to province, or region to region. What NERC does offer is a strong standard that system operators can target, or at least use as a benchmark for their own efforts.

### ***Co-ordinated planning***

Integrated power systems require at a minimum co-ordinated planning at the “seam”, or point of interconnection. However, transmission and generation development at any point in one power system has the potential to influence any interconnected system. For that reason, many interconnected regions have begun to actively co-ordinate transmission development plans. In Europe this is done through the Ten-Year Network Development Plan (TYNDP), and in the United States through a variety of bilateral and regional relationships. An example is the Eastern Interconnection Planning Collaborative (EIPC), which co-ordinates planning exercises among all

of the system operators in the eastern portion of the United States (this includes a mixture of restructured states and states with vertically integrated utilities; see Figure 4.8).

**Figure 4.8 • Proposed transmission development plans for members of the EIPC**



This map is without prejudice to the status of or sovereignty over any territory, to the delimitation of international frontiers and boundaries, and to the name of any territory, city or area.

Note: kV = kilovolt.

Source: Eastern Interconnection Planning Collaborative (EIPC), (2013), "Finalized Map of Solutions"<sup>3</sup>.

For the ASEAN countries, co-ordinated planning may mean developing national plans separately and then sharing them in a common forum. This would mean that each system operator develops and shares consistent data sets, that reliability requirements are harmonised, and that they use common – or, at least, comparable – planning models.

Co-ordinated planning in this fashion will most likely reveal areas where closer collaboration would be beneficial to all parties. For example, co-ordinated exercises reveal areas of common interest, where it would make more sense to embark on a joint project than to continue separately – for example, construction of a single larger generator instead of two smaller generators.

### ***Cost allocation of transmission development and wheeling charges***

Deciding how to share the cost of transmission development that cuts across two or more different territories can be a difficult exercise. Cost allocation methodologies that lack transparency, or do not fairly apportion the relevant costs can act as a significant barrier to development. Adding an additional layer of complexity is the fact that transmission development in one portion of the power system may require additional development elsewhere. It does little good to develop interconnections between Sarawak and Kalimantan, for example, if Sarawak does not have enough internal transmission capacity to deliver power to the border.

In general, transmission cost allocation should follow the "beneficiary pays" principle, which means that the cost of development should be shared in proportion to the degree that a given party benefits. This has the advantage of discouraging outside investment in projects that do not have sufficient benefits.

<sup>3</sup> [www.eipconline.com/uploads/20121127\\_EIPC\\_SSI\\_S1S2S3\\_Constraints\\_Solutions\\_print.pdf](http://www.eipconline.com/uploads/20121127_EIPC_SSI_S1S2S3_Constraints_Solutions_print.pdf).

For example, suppose two countries plan to build a transmission line that crosses through the territory of a third country, but that will not deliver power to that third country. The third country still bears some cost in the form of siting and the environmental impact of development. The reasonable action is for the first two countries to compensate the third country for those costs. Even in that case, however, determining how much of the cost should be borne by the first country and how much by the second should depend on who benefits more from the development of the transmission line.

If the third country has sufficient interconnection and transmission capacity to support energy transfer from the sending country to the receiving country (e.g. transfer from Lao People's Democratic Republic ["Lao PDR"] to Singapore will be through Thailand and Malaysia), new transmission lines need not be constructed. However, the countries involved must agree on suitable wheeling charges which compensate for possible line congestion and any other technical impacts of the transfer.

### *Revising network codes*

Network codes provide guidelines for participants in the electricity system on how to behave in order to maintain reliability, and how they should respond to unexpected events. Codes can be quite detailed or fairly loosely defined, and striking a balance between too little definition and too much can be difficult.

In general, network codes can be divided into three categories:

- i. **Connection codes** are the rules that determine how generators and large customers should act when connected to the grid.
- ii. **Operational codes** set the rules for how generators should behave in real time in order to maintain system stability including, for example, frequency control.
- iii. **Market codes** describe how power should be traded among relevant parties in all timescales – including long-term capacity obligations, day-ahead scheduling and balancing.

As the diversity of generator types and large users has changed, network codes have been required to change as well. For example, connection codes for systems with large amounts of base-load coal generation and limited variable renewables will not look the same as those for a system with high penetrations of wind and solar. In isolated systems, these differences do not matter. As systems interconnect, though, grid codes in base-load heavy systems need to be adjusted to reflect their increased exposure to variable power flows. At the same time, the performance of renewables may need to respond to the requirements of systems with less flexible power – for example, self-curtailing during times when production significantly exceeds demand.

Developing basic market codes will also be important for the ASEAN region, as integration can only function if power can be traded across borders. Common methods must be developed for allocating capacity, so that the power contribution from specific generators is not over- or undercounted.

Network codes and standards do not need to be completely standardised among co-ordinating countries, but they must be harmonised. Harmonisation means that codes implemented in one country do not interfere with those in another. For example, codes related to managing outages should be developed in such a way as to ensure that local outages can be managed without creating instabilities in neighbouring networks.



## System monitoring

Effective monitoring requires the collection of operating data, such as power generated, demand, losses and cross-border transmission. In interconnected environments, regulators should establish common data standards and collection practices. Two countries with excellent data collection methods may nevertheless have trouble integrating if differences in the way the data is presented can lead to differences of interpretation. In addition to collecting data in a consistent fashion, data should be shared among the relevant countries. This can be a sensitive issue, as some data – especially data collected on IPPs – may be proprietary. In addition to developing common practices for data collection and sharing, the ASEAN countries should develop common methods for protecting data that should not be made public.

Figure 4.9 • Data handling in a regional market



**Box 4.2 • Case study: Price coupling of regions in the European Union**

Europe, which has unbundled generation from transmission ownership and allows for complete competition between generators, is an interesting mix of national and supranational entities and policies. System operations are managed at the national or subnational level, but there are significant interconnections between countries, and so cross-border co-ordination is vital in order to maintain overall system security. One challenge has been how to efficiently manage the cross-border flows of power, given the lack of a common system co-ordinator. Europe has chosen to address this problem through the Price Coupling of Regions (PCR), a decentralised mechanism that aims to rationalise power flows between countries while still allowing for independent system operations. While PCR is specifically designed for restructured markets with wholesale electricity prices, there are some lessons that are relevant to fully vertically integrated environments that are seeking to integrate across borders.

At its core, PCR is simply an algorithm for determining day-ahead electricity prices and a method for sharing data. Countries share day-ahead bid and load data, and calculate prices independently using a common algorithm. One key advantage is that it allows for power market co-ordination while using existing national system operators – and thus removing the need for the creation of a common system co-ordinator. Energy markets are integrated while still maintaining independent control, which allows for the continuance of national policies while enabling the more efficient use of cross-border infrastructure. By focusing only on the day-ahead market, PCR avoids the complexity of managing real-time power flows, but allows system operators to plan for real-time operations with a better sense of the actual availability of external resources.

PCR also allows for a piecemeal approach to market integration. If a group of countries wishes to integrate their power markets, but are at different stages of market development or have differing levels of existing interconnections, subgroups of countries can elect to couple together first, with an eventual goal of complete price coupling among all countries.

The focus of PCR is on price formation, and as such it is not completely relevant to vertically integrated markets, which do not require a mechanism for setting the price of electricity on a wholesale level. Nevertheless, PCR does offer some lessons to the ASEAN region as a whole. First, in markets that trade power across borders, developing a mechanism to determine prices can make cross-border flows more efficient, even if those prices are only used as an internal accounting mechanism. In Europe, market unbundling did not, in and of itself, rationalise all power flows between countries. There were still a number of hours in which prices flowed from high-price regions to low-price regions. This is at a minimum inefficient, and at its worst potentially destabilising, as it implies that power is flowing away from regions with higher demand. Implementing PCR removed this inefficiency. Developing an internal price-setting mechanism also allows vertically integrated markets to more effectively trade power with markets that have developed wholesale markets – for example, Malaysia and Singapore.

Second, the key component of PCR is not the price-setting mechanism (which, in the end, is simply a common methodology for calculating prices in the day-ahead market), but rather the effort to implement data-sharing tools and standardise system procedures. Integrating systems across borders requires the regular sharing of information. When multiple markets are involved, having a common data-sharing mechanism avoids the complexity of needing to meet varying data requirements simultaneously. Even in the absence of market integration, data sharing provides system operators with benchmarks against which they can measure internal operations.

Finally, a PCR-like mechanism allows for the better use of internal and external resources. By establishing the true available transmission capacity between regions, PCR allows system operators to use existing assets in a more efficient fashion. In doing so, it can reduce the need to invest in additional infrastructure, or reveal where existing infrastructure is falling short.

## Policies to support power sector integration

There are two methods for integrating power systems: co-ordination and complete consolidation. Of the two, consolidation allows for the most effective management of power system operations and development. All system operations are merged under one central body, which can therefore optimise day-to-day operations and long-term development. Consolidated systems also require co-ordinated investment decisions. This does not mean that all investment decisions must be made by a central planner. Rather, investment decisions must be made in an open, transparent fashion so that they can be taken into account when developing long-term system plans, as unexpected capacity additions can lead to system congestion or instability. Consolidation has worked successfully in regions such as the company PJM Interconnections in the United States, where utilities in 13 states and the District of Columbia have given a single ISO control over dispatch decisions, market design and long-term planning. Despite the benefits, there are significant barriers to consolidation that must be considered.

Co-ordinated systems maintain existing control structures – either at the national or subnational level – while harmonising cross-border flows. This is the case in Europe, for example, where dispatch decisions are made within countries, but are co-ordinated between countries through the use of commonly managed European institutions. Another example is the Southern African Power Pool (see Box 4.4). One drawback to co-ordination is that it often leads to less efficient use of cross-border transmission capacity because of reliability concerns.

**Table 4.1 • Summary for co-ordination vs. complete consolidation**

Integration type	Co-ordination	Complete consolidation
<b>Main characteristics</b>	Maintain existing control structures – either at the national or subnational level – while harmonising cross-border flows.	All system operations are merged under one central body, which optimises day-to-day operations and long-term development.
<b>Example</b>	Europe. Dispatch decisions are made within countries, but are co-ordinated between countries.	PJM in the United States. Utilities in 13 states and the District of Columbia have given a single ISO control over dispatch decisions, market design and long-term planning.
<b>Effectiveness</b>	Less efficient use of cross-border transmission capacity.	Most effective management of power system operations and development.

Consolidation and co-ordination can coexist. For example, while some utilities in the United States have organised under PJM, others have organised under the mid-continent ISO (MISO). Within both PJM and MISO, operations are centralised. However, as PJM and MISO border each other, they must also co-ordinate cross-border flows in order to manage cross-border flows of electricity.

**Figure 4.10 • Example of coexistence for co-ordination and complete consolidation**

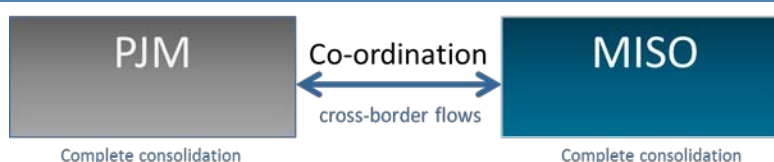

Similar structures involving both consolidation and co-ordination may be an appropriate goal for ASEAN. It may make sense to consolidate operations within some subregions, while co-ordinating within the region as a whole. The subregions may be based on the HAPUA vision of northern,

southern, and eastern systems. Each subregion would consequently need to establish a Regional Power Coordination Center (RPCC) according to the aim of the Greater Mekong Subregion (GMS) system.

### Models of co-ordination

The trade of electricity between two or more countries can be managed under a number of different arrangements, from simple, non-economic transactions based on mutual electricity security to complex multilateral trading systems. Within the ASEAN context, five main models for cross-border trading of electricity are worth examining:

1. unidirectional trades based on electricity cost differences
2. bilateral, bidirectional power trades between national utilities
3. imports from IPPs in neighbouring countries
4. trade with one or more intermediary countries
5. multi-buyer, multi-seller market.

Crucially, there is no single model that all ASEAN countries should adopt – at least not in the short term. Rather, cross-border trading among the ASEAN can be facilitated under some or all of these models, which can be implemented between countries with very different market structures. A basic requirement, however, is that country-level regulations and legal arrangements do not prevent cross-border trading or introduce strict barriers to this trade.

**Figure 4.11 • Unidirectional trade based on electricity cost differences**

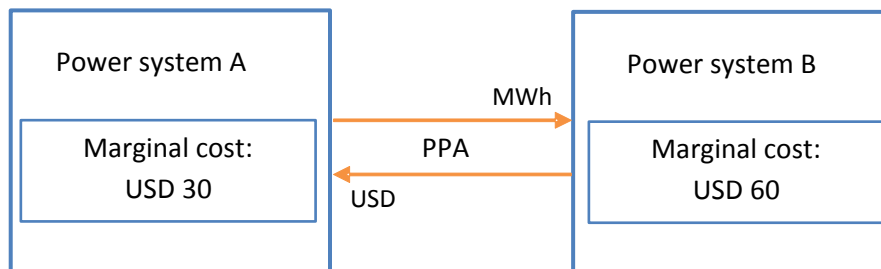

In this model, two national utilities enter into an agreement with one another, whereby the country with lower marginal cost electricity exports power to a neighbouring country with higher cost domestic resources. The power trade is usually structured under a long-term, fixed-price power purchase agreement (PPA) between the governments or the major utilities. If there is no existing (or insufficient) transmission capacity between the two countries, the utilities and/or the governments also have to enter into some kind of development and cost-sharing agreement. Typically, transmission costs are allocated on a “beneficiary pays” basis. Because, in a unidirectional transaction, the beneficiary would be the importing country, it makes sense that the cost of transmission development should fall on the importing country as well. Regardless, such an issue would need to be settled on a bilateral basis.

Such an arrangement could also be managed through a merchant transmission line, where a third party (usually private) owns and operates the transmission line. Unidirectional flow transactions fit well with the merchant model, which are usually based on the use of high-

voltage direct current (HVDC) transmission lines. In a merchant model, the merchant recovers the costs by charging a toll to one or both parties.

Between neighbouring countries, differences in marginal cost usually derive from variations in generation. For example, Lao PDR has significant hydroelectric resources, while Thailand mainly generates power domestically using natural gas-fired generation. As hydroelectric plants have a lower marginal cost than natural gas plants, it is economically attractive for Thailand to import power from Lao PDR. In fact, the two countries have been trading power continuously since the early 1970s.

**Figure 4.12 • Bilateral trade between neighbouring countries**

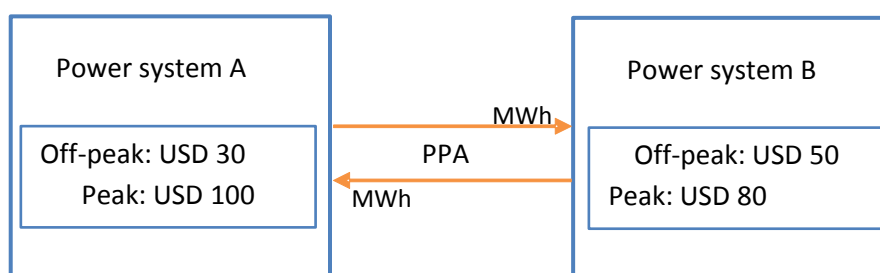

Bidirectional power transactions between two neighbouring countries present the opportunity to trade excess capacity, or to take advantage of inter-temporal cost differences. For example, one power system may have relatively low-cost off-peak power generation costs but high-cost peak generation costs, while its neighbour may be in the opposite situation. Such differences may also occur seasonally. For example, the first country may have excess hydro resources during a rainy season, but have insufficient domestic resources during a dry season.

Bilateral trade may also include short-term transactions and support during emergencies. In these circumstances, there may be no long-term agreement for power exchange in place, and therefore responsibility for operations and co-ordination falls on the respective system operators of each country.

Regardless of the circumstances, allowing bilateral trade requires an additional level of agreement between the countries in question. In particular, the two countries must agree up front on the nature of the agreement. Bilateral trade could be structured as a straightforward, zero-sum, fixed block power exchange, where each country agrees to export a certain amount of power over a certain period of time. An example among the ASEAN countries is the Malaysia-Singapore bilateral agreement and electricity trading in the GMS region (see Box 2.1). Alternatively, this arrangement could be structured as two PPAs, where each country agrees to export power to the other at a pre-arranged price.

Developing transmission lines between the two countries is more complex under a bilateral trade agreement than under a unidirectional one as, a priori, it is unclear which country is the main beneficiary. Under an agreement where trades are netted out to zero, both countries benefit equally, and so the cost of the transmission line could be split evenly between the two. However, even in such a case, one country may derive additional benefits – for example, increased electricity security – in which case it should bear more than half the cost.

**Box 4.3 • Managing interconnections**

Once interconnections between countries have been established, how they are managed plays a key role in the daily operations of each power system. Therefore, it is also critical to decide early on regarding the operation and maintenance responsibilities of each regulator to avoid overlaps and misunderstanding of roles. Additionally, matters pertaining to energy transfer must be managed in line with practice in the local electricity industry. For example, in the proposed arrangement of electricity trade from Lao PDR to Singapore, the Singapore market operation which trades on a real-time basis must be considered.

Two issues in particular must also be settled between the connected system operators: how to calculate network transfer capacity (NTC), and allocating network capacity in order to manage congestion. Transmission capacity is dependent on the thermal limit of the transmission line and on system-specific issues such as network topology or the potential for unplanned outages. As a result, the actual transmission capacity available on a given line may be significantly less than the theoretical limit (ENTSO-E, 2000).

Total transfer capacity (TTC) is the total capacity of the transmission line, given its thermal rating (which may vary depending on the season), the voltage range the line is designed for, and overall system stability, which depends on the structure of the network as a whole, among other factors. In practice, system operators prefer to avoid reaching a given line's TTC, in order to allow for some margin of error. Therefore, the TTC is reduced by a transmission reliability margin (TRM).

NTC is the amount of transmission capacity remaining after the TRM has been accounted for. It is therefore calculated as:

$$\text{NTC} = \text{TTC} - \text{TRM}$$

While this is formulaically straightforward, in practice deviations in how TTC and TRM are determined can have a significant impact on the final NTC. It is therefore important that the NTC for cross-border transmission lines be calculated in a co-ordinated manner, according to an agreed-upon methodology. Otherwise, each system operator runs the risk of over- or under-estimating the actual amount of transmission capacity available to them. It is also worth repeating that, as TTC is dependent on the overall network topology, changes to network infrastructure in one region can have an impact on the NTC in cross-border transmission lines, even if those changes are physically far removed. Therefore there is a strong case to be made for joint planning of interconnected power systems, at a minimum for transparent planning practices.

After the NTC is calculated, the remaining transmission capacity must be allocated to users who have some kind of commitment to it – for example, customers with long-term contracts with a particular generator. This is referred to as available transmission capacity (ATC). In Europe, allocation is done through physical transmission rights, which are forward-looking and may be allocated on an annual or monthly basis.

Finally, actual ATC can also change in real time, depending on which generators are running and the actual flow of power. This is the case for systems with large amounts of variable renewable generation, where actual generation can vary significantly from hour to hour. For this reason, systems operators must understand system conditions in all interconnected systems in as close to real time as possible, so they can take the appropriate steps in case of unexpected changes.

Figure 4.13 • A foreign IPP selling power to a national power utility in a neighbouring country

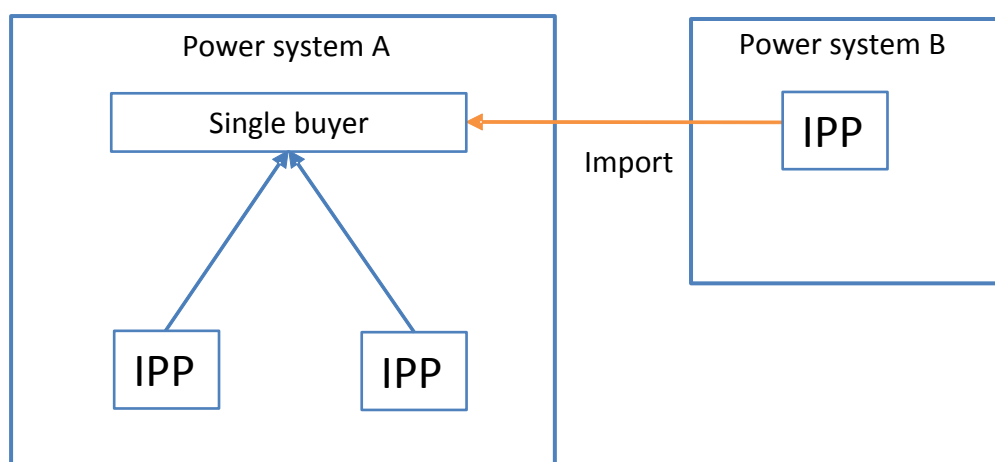

The foreign IPP model is in many ways similar to the unidirectional model. In this model, the national utility in one country procures power from an IPP operating in a neighbouring country. The participation of the foreign IPP can be arranged either on a long-term contractual basis or as a short-term purchase during energy shortfalls. In either case the national utility must have a framework in place that allows IPPs to participate in the power system. In most circumstances, the foreign IPP is treated equally with other domestic IPPs, which points to the main difference between this model and the unidirectional trade model. In a foreign IPP model, the IPP must compete with national IPPs.

Since the trade also involves the use of a cross-border transmission link, fees may also be charged for right of use. This model was practiced during the energy purchase by Tenaga Nasional Berhad (a Malaysian utility) from PowerSeraya (Singapore). Excessive fees can limit the ability of foreign IPPs to compete in a domestic market.

Utilities entering into an agreement with a foreign IPP must also take care to ensure they can rely on that power being available when it is needed. This means, in part, making sure the IPP does not overcommit itself by selling the same capacity twice – once to the national utility, and again to the utility in its own market. It also means understanding whether and in what circumstances the foreign system operator would curtail power from the IPP in the case of a system emergency.

As with unidirectional trade, the participation of a foreign IPP could be facilitated by a merchant transmission line operator. In some cases, the merchant line could bundle itself with the IPP as an “anchor tenant”, which may help with the development approval process and increase the merchant operator’s chance of obtaining funding.

### *Trade with one or more intermediary countries*

Often a country may seek to import power from a country or a resource that is not located immediately next door, but is instead one or more countries away. In such a case, the intermediary country or countries must be involved and must be compensated for the additional power flows that their system(s) must manage. Typically, such an arrangement can take one of two forms: the intermediary country buys power from the exporting country, and resells to the third country, or the importing and exporting countries enter into a wheeling agreement. In either case, agreements can be unidirectional or bidirectional.

Figure 4.14 • Purchase and resale of energy by an intermediate country

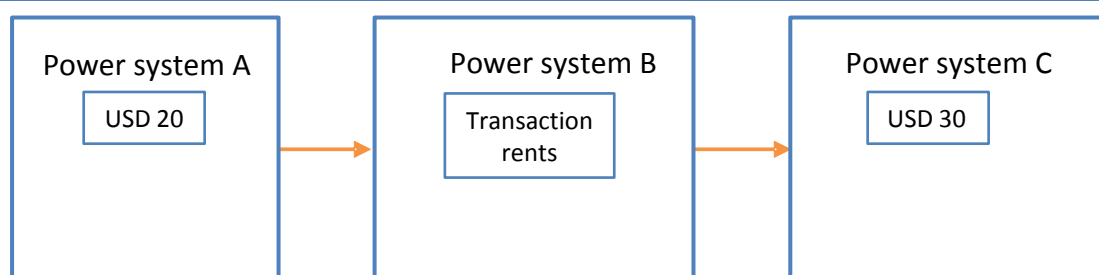

This model involves three (or more) parties where trading is enabled by the cost differences between the two trading countries. For instance, in the above diagram power system B buys cheaper electricity from power system A and subsequently sells to power system C at a higher price. At different times, the reverse may also hold true, whereby when the energy price is lower in C, B may procure and sell it to A.

Such an arrangement is relatively inefficient, as it gives country B the opportunity to capture rents from the transaction above the cost to its own system. However, in the case where there are only bilateral agreements between neighbouring countries, such an arrangement can be an intermediary step towards developing a more multilateral system. In this case, power system B enters into a bilateral agreement with power system A, and separately into a bilateral arrangement with power system C. With these agreements in place, power system B can theoretically buy and resell power from system A to system C, and vice versa, without having to go through the complex process of entering into a multilateral agreement. Over time, the bilateral agreements can be harmonised and combined into a single multilateral framework.

Figure 4.15 • Trade between two countries with third-party wheeling charges

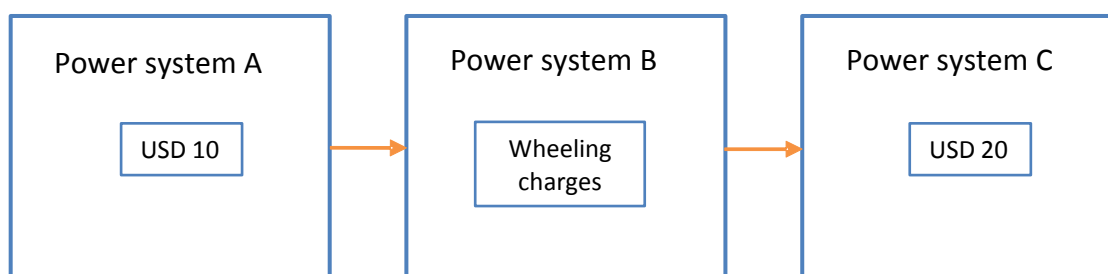

A more general model for the involvement of one or more intermediary countries is bilateral trade with third-party countries compensated through wheeling charges. Bilateral trades will generally involve some form of wheeling agreement in order to allocate the cost of transmission between the two parties. When a third party is involved the situation becomes more complicated, as the intermediary country must be compensated for use of its grid through the use of wheeling charges. In principle, the charge will be made up of transmission costs, losses, balancing, administration and any related taxes. For the buyer, the wheeling charge will also determine the cost efficiency for long-distance import.

However, the actual cost to the intermediary – and therefore the appropriate wheeling charge – can be difficult to quantify. To understand why, consider a situation where power system A wants to delivery power to power system C, through power system B, but power system B does not have sufficient transmission capacity to complete the trade. Power system B will therefore have to invest in new transmission lines. As this investment is the result of trade between power systems A and C, it is



reasonable that those two power systems should share the cost of the investment. However, power system B will also benefit from the investment, in the form of reduced congestion in its own system. Therefore, under the beneficiary pays principle, it should also bear some of the investment costs.

Once the wheeling charges have been established, the groundwork is laid for multilateral trades involving any of the countries involved. In addition, such an agreement can lay the foundation for a true multinational electricity market, as discussed below. There is, however, one last issue that must be address: the issue of priority.

Under normal system operations, there is no need to differentiate wheeled power flows from any other transaction within the intermediary power system. However, in the event of a contingency or in times of high congestion, the intermediary country will need to decide whether to prioritise its own system needs over those of its neighbour, or whether to meet its obligation to complete the transaction, potentially at the expense of the stability of its own system.

There is no one answer on how to handle the priority of wheeled transactions over domestic power system needs. If the importing country is only importing for economic reasons, it may be willing to forego the imports in exchange for fair compensation (e.g. the additional cost it had to bear to fill its power needs domestically). Alternatively, the importing country may be relying on the imports for its own needs, in which case the loss of imports could lead to its own system collapsing. What matters is that all parties in question agree, in advance, on how to handle system operations in the event of a disruption, and that the agreed-upon wheeling charges accurately reflect the true value that the intermediary country is providing to the transaction.

ASEAN is currently studying how to initiate cross-border power trade from Lao PDR to Singapore under the “Lao PDR, Thailand, Malaysia, Singapore (LTMS) Power Integration Project (PIP)”. The pilot is intended to complement existing efforts towards realising the ASEAN Power Grid (APG) and the ASEAN Economic Community (AEC), by creating opportunities for electricity trading beyond neighbouring borders. The project should help identify and resolve issues affecting cross-border electricity trading in ASEAN and demonstrate the technical viability of cross-border power trade of up to 100 MW from Lao PDR to Singapore through existing interconnections. This includes the examination of policy, regulatory, legal, and commercial issues relating to cross-border electricity trading (ASEAN, 2015).

Figure 4.16 • Multi-buyer, multi-seller market

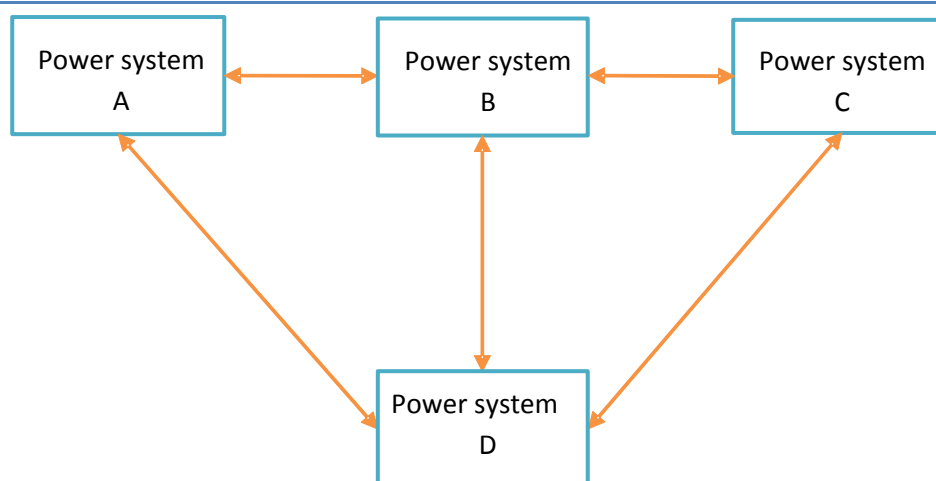

Once a regional transmission network has been established, it is possible to establish a multilateral market system. A multilateral market can allow for trading between any pair of member countries,

regardless of their domestic market arrangements. A multilateral system can also allow the participation of independent third parties (e.g. IPPs). Multilateral arrangements are complex and require significant investments in infrastructure, as well as some harmonisation of system operations. For that reason, multilateral markets may only make sense in the medium term for a subregion, or subregions, of ASEAN.

#### Box 4.4 • Case study: Southern African Power Pool

African power pooling represents yet another interesting experience how to pool electricity resources between a diverse set of countries and could provide interesting insights for the ASEAN integration discussion. Sub-Saharan Africa hosts four power pools: the West African Power Pool (WAPP), the Central African Power Pool (CAPP), the East African Power Pool (EAPP), and the Southern African Power Pool (SAPP). SAPP was created in 1995 and operates under the auspices of the Southern African Development Community (SADC), notably its Directorate of Infrastructure Services (DIS). The creation of SAPP was initiated by the ministers responsible for energy in the SADC region, and institutionalised by an inter-government memorandum of understanding (MoU).

Further relevant legal documents for the implementation and management of the SAPP are the Inter-Utility MoU (IUMoU), the agreement between operating members and the operating guidelines. These documents have been revised over time, reflecting the continuous need for flexible governance frameworks to respond to changing conditions.

SAPP is structured into an executive and a management committee as well as functional subcommittees for planning, operating, co-ordination, environment and markets. SAPP reports to the SADC DIS, which in turn reports to its Council of Ministers.

SAPP is made up of 16 utilities, independent transmission companies, and IPPs representing the countries of Angola, Botswana, the Democratic Republic of Congo, Lesotho, Malawi, Mozambique, Namibia, South Africa, Swaziland, Tanzania, Zambia, and Zimbabwe, which combined over 230 million people.

SAPP activities are funded through an annual contribution from all members using an agreed-upon formula defined in the IUMoU, and an administration fee levied on market participants. Projects relevant to the development of SAPP are mostly funded by international donors.

SAPP builds upon a fairly developed generation and transmission infrastructure, and was designed with the aim of optimising the use of the available energy resources and to ensure the reliable provision of electricity on an inter-regional basis. Its vision is to facilitate the development of a competitive and cost-efficient electricity market in the southern African region; to enhance competition for consumers; and to ensure sustainable energy developments through sound economic, environmental and social practices.

SAPP aims to achieve these targets through a set of activities such as the provision of a forum for the development of an interconnected electrical system with sufficient generation capacity in the southern African region; the co-ordination, harmonisation and enforcement of common regional standards; the facilitation of expert knowledge; and the implementation of strategies in support of sustainable development priorities.

SAPP initially built upon the common southern African practice of long-term bilateral supply contracts as already established in the 1950s. While these contracts continue to be the preferred method of energy exchange, since 2001 alternative ways of trading have been established and their use is expanding. In 2001 a SAPP short-term energy market (STEM), a post-STEM (balancing) market and a day-ahead market were established. There are also plans to add an ancillary services market, and to revisit existing markets to improve their performance and increase competition.

While a more competitive SAPP may help to better use the energy resources in the region, some immediate and short-term challenges remain. These include ensuring sufficient generation and adequate interconnection in a region with a rapidly growing demand for power, the migration from a co-operative pool to a competitive pool (including harmonised rules governing these exchanges), increasing liquidity, the implementation of cost-reflective tariffs and the adoption of regulatory principles that would enhance those tariffs, and the development and retention of trained and skilled personnel.

To establish a multilateral market, the participating countries must establish an independent cross-border market operator. The operator would be in charge of the monitoring and management of electricity trade between countries and would act as a platform for connecting buyers and sellers.

A multilateral market allows for differing levels of participation by member countries. Some may wish to only sell excess power, while devoting the rest of their capacity to domestic use. Others may choose to buy power only during times of scarcity. And some may choose to participate fully. All participating countries, however, must agree to give up some control over the allocation of interconnector capacity. Multilateral markets also allow for more efficient integration of renewable resources, and for participants to derive the full benefits of system flexibility.

### **Co-ordination and consolidation in the ASEAN context**

Given the diversity of countries within ASEAN, as well as geographic limitations, there is no single model of integration that fits ASEAN as a whole, at least in the short term. For example, although the consolidation of power systems has benefits in terms of better management of overall development and operation, the countries require completely aligned market and regulatory environments. It is possible to consolidate two completely vertically integrated power systems by simply creating one larger vertically integrated utility. Combining a vertically integrated market with a market that has undergone complete restructuring and divestment, however, would require that the vertically integrated utility give up all operating control and participate in open planning processes. Furthermore, consolidated markets also require the establishment of a single market operator with authority that stretches over multiple jurisdictions. Within ASEAN, this would mean two things: changes to national laws to grant authority to some third party, and the creation of an ASEAN-wide institution with additional powers and responsibilities.

**Figure 4.17 • Possible integration structure for the ASEAN region**

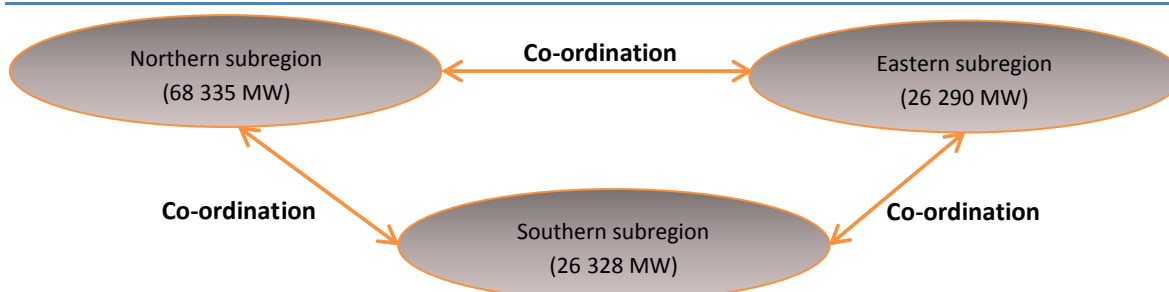

As a first step, it may make sense to create an ASEAN institution with limited authority to serve as a forum for collaboration. This forum could then evolve over time into a body with more significant control over inter-regional planning and co-ordination, at a pace in line with ASEAN development more broadly. The ASEAN Center for Energy (ACE) is currently working on harmonising technical standard codes for grid implementation between member countries. The ASEAN Energy Regulatory Network (AERN) specifically addresses the regulatory and legal framework for trade, investment and cross-border transmission of the APG. The Heads of ASEAN Power Utilities/Authorities (HAPUA) work to alleviate cross-border barriers in support of the implementation of the APG. These include the harmonisation of technical standards and systems, as well as an effective framework for harmonisation of business regulations including legal, taxation and pricing regulations to facilitate cross-border trade. HAPUA also established the ASEAN Power Grid Consultative Committee (APGCC) to assist in the implementation of the APG MoU.

Such working bodies within the ASEAN framework do not have enforcement or financial/political obligations to the ASEAN countries, and are based only on principles of co-operation. Unlike other intra-regional governance frameworks, ASEAN working bodies do not have the authority to require implementation by their member countries or funding from member states to jump-start regional investments. A medium-term goal, therefore, may be to consolidate some of these diverse responsibilities into one institution, with more explicit authority to co-ordinate policies among ASEAN countries.

## Conclusion and recommendations

Over the next two decades, the ASEAN countries will continue to see significant growth, both in their economies and in their demand for energy. This will require investment in both new generation and grids. In some cases, investment will have to outpace both economic growth – which will drive both increased industrialisation and wealth – and the increase in demand that will come from continued electrification. While the challenges for each country are significant, regional collaboration and the adoption of certain best practices can help in addressing and balancing the power system trilemma of sustainability, availability and affordability. With this in mind, this report recommends the following policies and steps to support the continued development of regional electricity markets:

1. **Establish strong, stable, and rules-based governance frameworks to ensure sufficient investment and efficient operations:** Regional collaboration does not mean sacrificing regional diversity, but appropriate governance frameworks must be in place for the power sectors to function, whether they are liberalised or fully regulated. A depoliticised power system with clear and reliable governance and regulatory frameworks is necessary to establish reliable business cases that will attract private sector investment and make optimal use of the power system as a whole, regardless of the market structure. Governing policies that support the identification, development and operation of an adequate mix of supply- and demand-side technologies are crucial to ensure the efficiency and reliability of cross-border or regional power trading.
2. **Separate generation and transmission development under transparent, rules-based regulatory systems:** Power sector reforms, such as the passage of appropriate electricity legislation that provides clear policy mandates, commercialisation and account unbundling, and the establishment of an independent regulatory body can all be carried out while maintaining a single-buyer arrangement. Indeed, under a single-buyer model, a strong and independent regulator is necessary in order to ensure that IPPs and generation alternatives such as demand-response can participate on a level playing field with the incumbent utility. Regardless of how generation ownership and development is managed, transmission development should remain the responsibility of a regulated institution regardless of the institutional frameworks in place. However, ensuring open access to third parties, efficient investment and operations, and secure inter-regional integration requires transmission planning that is fully transparent and carried out in an inclusive environment. Interconnections need to be planned in co-ordination with generation development.
3. **Establish an ASEAN industry-government co-ordination committee on grid codes:** It is possible for countries to maintain domestic priorities while benefiting from regional co-operation, so long as certain practices are harmonised. Grid code harmonisation should be a concerted effort involving governments, utilities and other relevant public and private stakeholders. Therefore, there is a need to establish a grid code co-ordination committee which will deliberate on the current status and advise on how best to bridge differences.
4. **Establish a regional regulatory body:** In addition to the importance of national regulators, this report highlights the important long-term goal of establishing a regional regulatory institution as a further step beyond the establishment of a committee on grid codes. This organisation should have a clear mandate and support from all member countries, and be granted the authority to work with national regulators to standardise reliability requirements and grid codes and focus on cross-border capacity planning and

allocation. It can also take on the responsibility of ensuring regional energy security and associated contingency plans, and establishing cost-sharing rules for cross-border projects, as well as wheeling tariffs. To ensure its sustainability, this body should be equipped with a permanent budget and staff. Therefore, it should be established at an agreed-upon location and steadily funded by contributions from each member country. For example, Lao-Thailand-Malaysia-Singapore Working Group and the existing ASEAN regulators network could be the basis for establishing such a regulator.

5. **Support long-term growth by investing in higher voltage interconnections:** The growth in ASEAN electricity demand can be more efficiently met by establishing long- and medium-term regional plans to add capacity and expand or upgrade transmission grids. Integrated planning can unlock the full potential of optimising resources and investment efficiency. Fuel diversification can also be encouraged through regional planning by pooling resources. Having clear and agreed-upon plans can also translate to savings of both time and cost. For example, building a higher rated 500 kVA transmission line to cater for long-term forecasted demand growth is better than building a lower rated 250 kVA lines which would only have to be upgraded at some later date to meet future demand. Regional planning and cost-sharing allow for larger investments than would otherwise be possible.
6. **Consider the full lifetime cost of investment for generation planning:** While keeping in mind each country's policy objectives and social obligations, generation planning should involve a comprehensive cost comparison among multiple technologies. That is, the type of new plant to be developed should not be predetermined without considering the merits of alternative technologies. For example, although the current least-cost technology is the subcritical coal-fired generator, environmental externalities, uncertainties around future fuel costs, and the rapidly decreasing cost of renewable alternatives means this may not necessarily be the best option for the long term. Regional collaboration on generation development would allow ASEAN utilities to invest in newer technologies with higher efficiency and lower emission levels, which means less exposure to fuel price volatility and fewer environmental retrofits. Ideally, generation costs should take into account externalities such as sulphur dioxide (SO<sub>2</sub>) and nitrogen oxide (NO<sub>x</sub>) emissions (both of which contribute to acid rain, which can have a devastating impact on agriculture, jungles and forests), and CO<sub>2</sub>, a greenhouse gas and major contributor to climate change.
7. **Extend regional planning to include renewable generation technologies:** ASEAN member countries have recognised that renewable sources bring about multiple benefits, including direct reductions in emissions. Expansion of renewable energy will benefit significantly both from deployment that takes into account optimal resource availability, and from the economies of scale that can come from serving larger loads. Although the upfront cost is generally higher than coal or gas turbines, these sources have no fuel cost. Streamlined and harmonised policies and support schemes will benefit the utilities, grid operators and investors. To spur more investment, it is recommended that ASEAN countries look beyond the widely implemented feed-in-tariff. For example, individual or groups of countries could hold auctions for large-scale wind or solar projects to be built in one country but bought by one or more other countries. These could start as technology-specific auctions, but could evolve over time into those that are technology neutral, for example location-specific auctions that allow all technologies to compete to see who can provide the cleanest generation option at the lowest cost in a given location. Efforts to expand renewables should also be supported by working to improve power system flexibility, in order to integrate variable renewable resources while maintaining reliability.

8. **Capitalise on endogenous resources and technological capabilities for renewables:** In some cases, the specific renewable energy technology choice is clear. For example, the Greater Mekong Subregion has vast hydropower resources, with Lao PDR already identified as the “battery of Asia”. ASEAN countries should also capitalise on their current strength as developing nations with manufacturing capabilities. Currently, many PV module manufacturers are located in Malaysia, the Philippines and Thailand; therefore, demand for photovoltaic systems may potentially be met through intra-ASEAN acquisition. However, local content should not be given explicit priority over content sourced from outside the region. Exposure to competition is the best way to provide incentives to improve both cost and quality.
9. **Devise strategic programmes to encourage private sector investment:** To secure adequate funding, the APAEC includes strategic programmes that prioritise private sector participation and co-operation of non-ASEAN countries. For example, the APG is supported by cost-sharing principles followed by national oil and gas companies and national power utilities. This type of arrangement should be emulated for future projects. Once integrated regional frameworks for investment and regulation have been established, this could also assist in calming investors’ concerns about regional political stability. Similarly, harmonisation of regulations and standards is necessary to achieve gains from trade in natural resources and electricity, and to benefit from market-led investments and trade.
10. **Use the experience gained from the upcoming Lao PDR-Singapore multilateral trade project (and related grid upgrades):** This project can serve as a case study in how to plan and manage future interconnections and the development of the full ASEAN Power Grid. Although a fully consolidated regional market may not be feasible in the near future, the general aim should be to foster closer co-operation to make optimal use of all investments. Efforts towards furthering the APG should be fully supported and given high priority.

## References

- ADB (Asian Development Bank) (2013), *Energy Outlook for Asia and the Pacific*, ADB, Manila, Philippines.
- ADB (2003), *Special Evaluation Study of Cost Recovery in the Power Sector*, ADB, Manila, Philippines.
- AEMI Group (2013), *ASEAN Energy Market Integration (AEMI): From coordination to integration*, ASEAN Studies Center, Chulalongkorn University, Bangkok, Thailand.
- ASEAN (2015), Joint Statement of the Lao PDR, Thailand, Malaysia and Singapore Power Integration Project (LTMP PIP), [www.mti.gov.sg/NewsRoom/SiteAssets/Pages/Joint-Statement-of-the-Lao-PDR,-Thailand,-Malaysia-and-Singapore-Power-Integration-Project-\(LTMS-PIP\)/JointPressStatementCrossBorder.pdf](http://www.mti.gov.sg/NewsRoom/SiteAssets/Pages/Joint-Statement-of-the-Lao-PDR,-Thailand,-Malaysia-and-Singapore-Power-Integration-Project-(LTMS-PIP)/JointPressStatementCrossBorder.pdf).
- Booz & Company (2013), “Benefits of an Integrated European Energy Market”, report prepared for DG Energy, Booz & Company, [http://ec.europa.eu/energy/infrastructure/studies/doc/20130902\\_energy\\_integration\\_benefits.pdf](http://ec.europa.eu/energy/infrastructure/studies/doc/20130902_energy_integration_benefits.pdf), (accessed 11 February 2014).
- EIPC (Eastern Interconnection Planning Collaborative) (2013), “Finalized Map of Solutions”, [www.eipconline.com/uploads/20121127\\_EIPC\\_SSI\\_S1S2S3\\_Constraints\\_Solutions\\_print.pdf](http://www.eipconline.com/uploads/20121127_EIPC_SSI_S1S2S3_Constraints_Solutions_print.pdf).
- EPPO (Energy Policy and Planning Office) (2001), “Electricity outage cost study”, [www.eppo.go.th/power/ERI-study-E/ERI-ExeSummary-E.html](http://www.eppo.go.th/power/ERI-study-E/ERI-ExeSummary-E.html).
- ERIA (Economic Research Institute for ASEAN and East Asia) (2014), *Investing in Power Grid Interconnection in East Asia*, Jakarta, ERIA.
- ENTSO-E (European Network of Transmission System Operators for Electricity) (2000), “Net Transfer Capacities (NTC) and Available Transfer Capacities (ATC) in the Internal Market of Electricity in Europe (IEM) Information for User”, [www.entsoe.eu/fileadmin/user\\_upload/\\_library/ntc/entsoe\\_NTCUsersInformation.pdf](http://www.entsoe.eu/fileadmin/user_upload/_library/ntc/entsoe_NTCUsersInformation.pdf).
- GIZ (Deutsche Gesellschaft für Internationale Zusammenarbeit, GmbH) (2013), “It's more sun in the Philippines: Facts and figures on solar energy in the Philippines. Project Development Programme (PDP) Southeast-Asia”, [www.giz.de/fachexpertise/downloads/giz2012-en-pv-in-the-philippines-policy-brief.pdf](http://www.giz.de/fachexpertise/downloads/giz2012-en-pv-in-the-philippines-policy-brief.pdf).
- HAPUA (Heads of ASEAN Power Utilities Authorities) (2015), presentation by HAPUA Secretary at 21st HAPUA Working Group Meetings, Melaka, Malaysia, May 2015.
- Hausman W. et al. (2014), “Multilateral and bilateral aid policies and trends in the allocation of electrification aid, 1970-2001”, *Utilities Policy*, Vol. 29, pp. 54-62.
- Hausman, W. et al. (2008), *Global Electrification: Multinational Enterprise and International Finance in the History of Light and Power, 1878–2007*, Cambridge University Press, New York.
- Hogan, W.W. (1998), “Competitive electricity market design: A wholesale primer”, Harvard University, Cambridge, MA. [www.hks.harvard.edu/fs/whogan/empr1298.pdf](http://www.hks.harvard.edu/fs/whogan/empr1298.pdf).
- Hunt, S. (2002), *Making Competition Work in Electricity*, Wiley, New York.
- IEA (2015a), *World Energy Outlook Special Report 2015: Southeast Asia Energy Outlook*, OECD/IEA, Paris.



- IEA (2015b), *Electricity Information* (database), OECD/IEA, Paris, [www.iea.org/statistics/](http://www.iea.org/statistics/), (accessed August 2015).
- IEA (2014a), “The Power of Transformation”, presentation to Electricity Security Advisory Panel Workshop of Scarcity and Flexibility Pricing, 2 July 2014, Paris.
- IEA (2014b), *Seamless Power Markets: Regional Integration of Electricity Markets in IEA Member Countries*, Featured Insight, OECD/IEA, Paris.
- IEA (2013a), *World Energy Outlook Special Report 2013: Southeast Asia Energy Outlook*, [www.iea.org/publications/freepublications/publication/SoutheastAsiaEnergyOutlook\\_WEO2013SpecialReport.pdf](http://www.iea.org/publications/freepublications/publication/SoutheastAsiaEnergyOutlook_WEO2013SpecialReport.pdf), OECD/IEA, Paris.
- IEA/NEA (forthcoming), *Projected Costs of Generating Electricity 2015*, OECD/NEA, Paris.
- Jamasb, T. et al. (2014), “Energy sector reform, economic efficiency and poverty reduction”, School of Economics Discussion Paper No. 529, The World Bank, Washington, D.C.
- Jamasb, T. and M.G. Pollit (2005), “Electricity market reform in the European Union: Review of progress toward liberalization and integration”, *The Energy Journal*, Vol. 26, Special Issue, pp. 11-41.
- Jarvis, D.S.L. (2010), “Institutional processes and regulatory risk: A case study of the Thai energy sector”, *Regulation & Governance*, Vol. 4, Issue 2, pp. 175–202.
- Joskow, P.L. (2008), “Lessons learned from electricity market liberalization”, *The Energy Journal*, Special Issue, “The Future of Electricity: Papers in Honor of David Newbery”, <http://web.mit.edu/cron/project/urban-sustainability/>.
- Kessides, I.N. (2004), *Reforming Infrastructure. Privatization, Regulation; and Competition*, A World Bank Policy Research Report, World Bank, Washington, D.C. <http://documents.worldbank.org/curated/en/2004/01/4297210/reforming-infrastructure-privatization-regulation-competition>, (accessed 9 May 2015).
- McConnell, D. (2012), *Impact of Renewable Generation on the Philippine Wholesale Electricity Spot Market: A report to the National Renewable Energy Board*, Melbourne Energy Institute. <http://mei.insights4.net.au/documents/impact-renewable-generation-philippine-wholesale-electricity-spot-market> (accessed 9 May 2015).
- Meier, P. et al. (2015), *The Design and Sustainability of Renewable Energy Incentives – An Economic Analysis*, World Bank, Washington, D.C.
- Ondraczek, J., N. Komendantova and A. Patt (2015), “WACC the dog: The effect of financing costs on the levelised cost of solar PV power”, *Renewable Energy*, Vol. 75, March 2015, pp. 888-98.
- Platzer, M. D. (2015), *U.S. Solar Photovoltaic Manufacturing: Industry Trends, Global Competition, Federal Support*, UNT Digital Library, Washington D.C. <http://digital.library.unt.edu/ark:/67531/metadc93931/> (accessed 9 May 2015).
- Praktiknjo, A. (2013), *Energy Supply Security* (in German), Springer-Verlag.
- REN21 (Renewable Energy Network for the 21st Century) (2015), *Renewables Global Status Report 2014*, [www.ren21.net/gsr](http://www.ren21.net/gsr), (accessed 9 May 2015).
- Sensfuß, F. et al. (2008), “The merit-order effect – A detailed assessment of the impact of renewable electricity generation on the German electricity sector: An agent-based simulation approach”, *Energy Policy*, Vol. 36, No. 8, pp. 3086-94.
- Singapore Government (2015), “Energy Market Authority”, website, [www.ema.gov.sg](http://www.ema.gov.sg).

Syaiful, I. (2015), “ASEAN power market integration”, presented at ACE-HAPUA-IEA-World Bank Workshop, 13 March 2015.

Vagliasindi, M. and J. Besant-Jones (2013), *Power Market Structure: Revisiting Policy Options*, World Bank, Washington, D.C., <http://documents.worldbank.org/curated/en/home>.

Vongsay, A. (2013), “Energy Sector Development in Lao PDR”, presented at Energy Policy Training Course, Tokyo Japan, 24-June – 12 July 2013.

World Bank (2015), *Private Participation in Infrastructure* (database), <http://ppi.worldbank.org/index.aspx> (accessed 9 May 2015).

World Bank (1993), *The World Bank’s Role in the Electric Power Sector: Policies for Effective Institutional, Regulatory, and Financial Reform*, World Bank, Washington, D.C.

# Acronyms, abbreviations and units of measure

## Acronyms and abbreviations

AC	alternating current
ACE	ASEAN Center for Energy
AEC	ASEAN Economic Community
AEMI	ASEAN Energy Market Integration
AERN	ASEAN Energy Regulatory Network
AGTP	APG transmission planning
AMEM	ASEAN Ministers of Energy Meeting
APAEC	ASEAN Plan of Action for Energy Cooperation
APG	ASEAN Power Grid
APGCC	ASEAN Power Grid Consultative Committee
ASEAN	Association of Southeast Asian Nations
ATC	available transmission capacity
ATSO	APG transmission system
BPMC	Berakas Power Management Company Sdn Bhd
CAGR	compound annual growth rate
CAPEX	capital expenditure
CAPP	Central African Power Pool
CCGT	combined cycle gasification turbine
CfD	contract for difference
CO <sub>2</sub>	carbon dioxide
CSP	concentrated solar power
DIS	Directorate of Infrastructure Services
EDL	Electricité du Laos
EE	Energy efficiency
EGAT	Electricity Generating Authority of Thailand
EIPC	Eastern Interconnection Planning Collaborative (US)
ENTSO	European Network of Transmission System Operators
EPPO	Energy Policy and Planning Office (Thailand)
FDI	foreign direct investment
FERC	Federal Energy Regulatory Commission (US)
FiT	feed-in tariff
GDP	Gross domestic product
GMS	Greater Mekong Subregion (Programme)
HAPUA	Heads of ASEAN Power Utilities / Authorities
HVDC	high-voltage direct current
IEA	International Energy Agency
IPP	independent power producer
IRP	integrated resource planning

ISO	independent system operator
IUMoU	inter-utility memorandum of understanding
LCOE	levelised cost of electricity
LOLE	Loss of Load Expectation
MEA	Metropolitan Electricity Authority (Thailand)
MoU	memorandum of understanding
MSS	market support services
NERC	North American Electric Reliability Corporation
NREB	National Renewable Energy Board (Philippines)
NTC	network transfer capacity
OPEX	operating expenditure
PCR	Price Coupling of Regions
PDP	power development planning
PEA	Provincial Electricity Authority (Thailand)
PHP	Philippine peso
PLN	Perusahaan Listrik Negara (Indonesian State Electricity Company)
PPA	power purchase agreement
PURPA	Public Utility Regulatory Policies Act
PV	photovoltaic
RAP	Regulatory Assistance Project
RE	renewable energy
RPCC	Regional Power Coordination Center
RPS	renewable energy portfolio standards
SADC	Southern African Development Community
SAL	structural adjustment loan
SAPP	Southern African Power Pool
STEM	short-term energy market
T&D	Transmission and development
TAGP	Trans-ASEAN Gas Pipeline
TGC	tradable green certificate
TPA	third-party access
TRM	transmission reliability margin
TSO	Transmission system operators
TTC	total transfer capacity
TYNDP	Ten-Year Network Development Plan (EU)
UNFCCC	United Nations Framework Convention on Climate Change
vRES	variable renewable energy sources
WAPP	West African Power Pool
WESM	wholesale electricity spot market

## Units of measure

EJ	exajoule
Gt	gigatonne
Gtoe	gigatonnes of oil-equivalent
GW	gigawatt
GWh	gigawatts per hour
Hz	hertz
km	kilometre
kV	kilovolt
kWh	kilowatt hour
mtoe	million tonnes of oil-equivalent
MW	megawatt
TWh	terawatt hour
V	volt

# Online bookshop

[www.iea.org/books](http://www.iea.org/books)

PDF versions at 20% discount

E-mail: [books@iea.org](mailto:books@iea.org)

International Energy Agency



Secure Sustainable Together

Energy Technology Perspectives series

World Energy Outlook series

Energy Policies of IEA Countries series

Energy Statistics series

Oil

Medium-Term Market Reports series

Renewable Energy

Energy Efficiency Market Report

Energy Policies Beyond IEA Countries series

Coal

Gas

This document and any map included herein are without prejudice to the status of or sovereignty over any territory, to the delimitation of international frontiers and boundaries and to the name of any territory, city or area.

This publication reflects the views of the International Energy Agency (IEA) Secretariat but does not necessarily reflect those of individual IEA member countries. The IEA makes no representation or warranty, express or implied, in respect to the publication's contents (including its completeness or accuracy) and shall not be responsible for any use of, or reliance on, the publication.

IEA Publications

9, rue de la Fédération, 75739 Paris cedex 15

Typesetting by Jouve - Printed in France by IEA, September 2015

Cover design: IEA. Photo credits: © Top : Flickr - Forgemind ArchiMedia; Middle : Flickr - IQRemix;  
Bottom : GraphicObsession



## ***Development Prospects of the ASEAN Power Sector***

### **Towards an Integrated Electricity Market**

For the Association of Southeast Asian Nations (ASEAN) countries seeking to meet the expected growth in electricity demand in coming decades, investment in additional generating capacity and grids that is both sustainable and cost-effective will be the biggest challenge. A regional ASEAN Power Grid (APG) would address this challenge by connecting countries with surplus power generation capacity to those facing a deficit; this would allow ASEAN countries to meet rising energy demand, improve access to energy services and reduce the costs of developing an energy infrastructure. An interconnected power system could also further enhance the development and integration of variable renewable power generation capacity, which would bring benefits such as enhanced energy security and environmental sustainability.

Principally, development of the power sector needs a strong, reliable and depoliticised governance framework. A precondition for such a governance framework is a strong, independent regulator at the national level. Accordingly, any regulatory authority must be formally separated from the executive branch and governed by statute without executive political influence on the regulation process.

But regulation must go beyond national borders if the APG is to flourish. While a fully consolidated regional market may not be achievable in the foreseeable future, ASEAN member countries should work closely together to set common long-term goals aimed at harmonising grid codes and reliability standards. To this end, an independent regional regulator should be established and given a mandate to look after the common benefits and interests of the ASEAN member countries.